

Fenner



Shaft Mounted Speed Reducers SMSR Plus Series

11

SMSR Plus - Helical
Gear Boxes

The Fenner Shaft Mounted Speed Reducer Plus Series is metric in design throughout and conforms to I.S.O. Preferences. A Shaft Mounted Speed Reducer provides a very convenient method of reducing speed, since it is mounted directly on the driven shaft instead of requiring foundations of its own. It eliminates (1) the use of one, and sometimes two, flexible couplings and (2) external belt take-up arrangements.



Shaft Mounted Speed Reducer Plus Series

A torque-arm anchors the Reducer and provides quick, easy adjustment of the V-Belts by means of its turnbuckle. Fenner Speed Reducer is manufactured in eight gear case sizes, designated by the letters B through to J. The eight sizes may have any one of three nominal gear ratios, 5: 1, 13: 1 & 20: 1.

A very wide choice of final driven speed can be determined by the use of an appropriate input V -Belt drive. The units will normally be oil lubricated, but they are equally suitable for "lubricated for life" greases.

Salient Features of PLUS Series SMSR:

- Improved Power Rating
- Backstop removal and assembly made easy
- Separate provision for fixing the Torque arm without opening casing assembly bolts.
- Compact Design results in improved performance of Equipment.

SELECTION PROCEDURE

(a) Service Factor

From Table 11-01 select the service factor applicable to the drive.

(b) Design Power

Multiply the absorbed power (or motor power if absorbed power not known) by the service factor chosen in step (a).

Note: Ensure that design power exceeds motor rated power.

(c) Peak Load

Divide any peak load by two

(d) Unit Selection

Using the greater value of steps (b) and (c) refer to the Power Rating Tables 11-09. and select the correct size of unit. The choice of single or double reduction gearbox will be determined by the output speed required. The normal operating speeds for each of the gearboxes may be observed in the Power Rating Tables. For other speeds consult Fenner.

Note: 5:1 units require special selection when fitted with backstops. Consult Fenner.

Selection of Associated Drive for 1440 rev/min Electric Motors

(e) **Output Speed:** Refer to the Drive Selection Tables (11-10 to 11-21) and under the appropriate gearbox size and ratio read down the column headed 'Output Speed' until an output speed equal or near to that required is found.

(f) **Pulley Diameters:** Read across from the chosen output speed to obtain both driving and driven pulley pitch diameters and the appropriate number of belts.

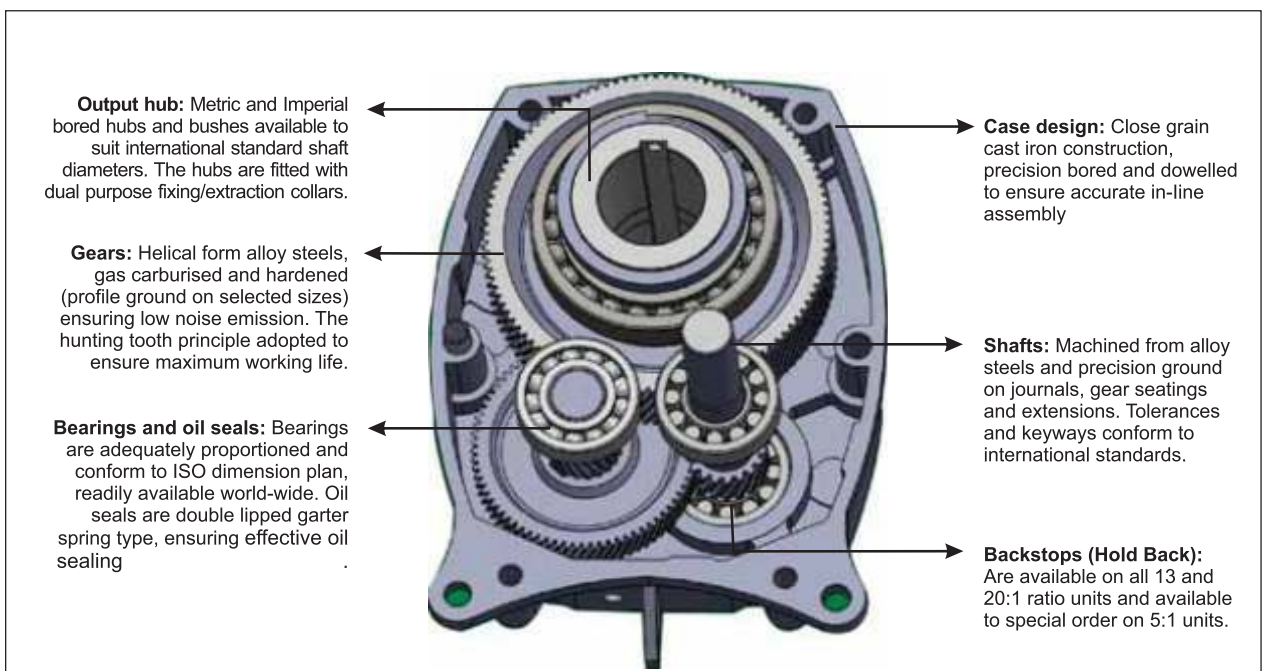

Shaft Mounted Speed Reducer Plus Series

(g) **Centre Distance:** Belt length and centre distance can be found from Drive Design Manual.

Selection of Associated Drive for Driving Speeds other than 1440 rev/min

(h) **Design Power:** Obtain from the Power Rating Tables the rated power of the gearbox at the required output speed and use it as the design power for the drive.

(i) **Gearbox Input Shaft Speed:** Multiply the gearbox output speed by the exact gear ratio (found in Table 11-04A) to obtain the gearbox input shaft speed.

(j) **Selection of V-Drive:** By referring to pages 11-11-22 of Fenner Drive Design Manual, a suitable belt drive can be chosen. It is advisable not to select a gearbox pulley smaller than that shown in the drive tables for the approximate speed required.

EXAMPLE

Table:11-01 - Service Factors

Types of Driven Machine	Operational Hours Per Day		
	Under 10	10 to 16	16 and over
Uniform Agitators and Mixers-liquid or semi-liquid Blowers -centrifugal Bottling Machines, Conveyors and Elevators - uniformly loaded Cookers, Laundry Washing Machines -non-reversing Line Shafts, Pumps - centrifugal and gear,Wire Drawing Machines	1.0	1.12	1.25
Moderate Shock Agitators and Mixers - variable density Conveyors - not uniformly loaded, Cranes-travel, motion and hoisting, Draw bench,Feeders - pulsating load Hoists, Kilns Laundry Tumblers, Lifts, Piston Pumps - with 3 or more cylinders, Pulp and Paper Making Machinery, Rubber Mixer. and Calenders, Rotary Screens, Textile Machinery	1.25	1.4	1.6
Heavy Shock Brick Presses, Briquetting Machines, Conveyors - reciprocating and shaker, Crushers, Feeders - reciprocating, Hammer Mills, Piston Pumps - 1 or 2 cylinders, Rubber Masticators, Vibrating Machines	1.6	1.8	2.0

A Shaft Mounted Speed Reducer is required for a uniformly loaded elevator which absorbs 3.6 kW at 48 rev/min. The prime mover is a 4 kW, 1440 rev/min direct-on-line start electric motor. A V-Belt drive is required between the motor and the gearbox at approximately 600 mm centres running for upto 24 hours/day.

SOLUTION

(a) **Service Factor:** From Table 11-01 the service factor is 1.25

(b) **Design Power:** Select on a basis of absorbed power ensuring that the design power exceeds the basic motor power.

$$\text{Design Power} = 1.25 \times 3.6 = 4.5 \text{ kW}$$

(c) **Peak Load:** Assuming that a direct-on-line start can exert 240% of full load torque.

$$\text{Peak Load} = \frac{4 \times 240}{2 \times 100} = 4.8 \text{ kW}$$

(d) **Unit Selection:** Using 4.8 kW as the basis for selection (being the greater value of steps (b) and (c)), reference to the Power Rating Tables 11-09 indicates that an E13 or E20 gear unit will transmit 6.22 kW at 48 rev/min.

(e) **Output Speed :** A cheaper belt drive will be obtained if the 20: 1 ratio gearbox is selected, and by reference to page 11-18 in the Gearbox Drive Tables. 48 rev/min is obtainable.

(f) **Pulley Diameters :** On the line giving the output speed of 48 rev /min, read across and note the driving and driven pulley pitch diameters together with the numbers of belts required, which for this case is 95 mm and 140 mm, using 2 SPZ Wedge Belts.

(g) By reference to the Wedge Belt catalogue, SPZ 1600 Belts can be selected to give 615 mm centres.

Note: Wedge Belt drives shown on pages 11-11- 22 have been selected to give the most economical total drive package for the speed required. If it is necessary to design a special drive it is advisable not to select a gearbox pulley smaller than that shown in the drive tables for the approximate speed required.



Shaft Mounted Speed Reducer Plus Series

Table:11-02 Output Hubs & Bushes

Reducer Size	Dimension 'B' (See Page 11-06)				
	Standard Hub Bore	Bush Bores for Standard Hub	Alternative Hub Bore	Bush Bores for Alternative Hub	
SMSR - PLUS	B05 B13 B20	30	25 1"	40	35 1¼" 32
	C05 C13 C20	40	35 1¼" 32 30	50	45 1¼" 42 1½" 38
	D05 D13 D20	50	45 1¾" 42 1½" 40 1¼" 38	55	2"
	E05 E13 E20	55	50 2" 45 1¾" 42 1½"	65	60 2¼"
	F05 F13 F20	65	60 2¼" 55 50	75	70 2¼" 2½"
	G05 G13 G20	75	70 2¾" 65 2½" 60 2¼"	85	80 3"
	H05 H13 H20	85	80 3" 75 2¾" 70 2½"	100	95 3½" 90
	J05 J13 J20	100	95 3½" 90	120	110 4½" 4"

All dimensions are subject to alteration without notice:

All dimensions are in millimeters unless otherwise stated.

Metric hubs are bored to F7 limits.

Inch hubs are bored to H7 limits.

Shaft keyways must be to appropriate standard dimensions,

i.e. to B.S. 4235/IS : 2048 for metric shafts and B.S. 46 for inch shafts.

Table:11-03 Standard Keyways

Shaft Diameter (mm)	Keysize	Shaft Diameter (inches)	Keysize
20	6 x 6	¾"	⅜" x ¼"
25	8 x 7	1"	¼" x ¼"
30	8 x 7	1 ¼"	⅝" x ¼"
32	10 x 8	1 ½"	⅜" x ¼"
35	10 x 8	1 ¾"	7/12" x ⅝"
38	10 x 8	2"	½" x ⅝"
40	12 x 8	2 ¼"	⅝" x 7/16"
42	12 x 8	2 ½"	⅝" x 7/16"
45	14 x 9	2 ¾"	¾" x ½"
50	14 x 9	3"	⅞" x ⅝"
55	16 x 9	4"	1" x ¾"
60	18 x 11	4 ½"	1 ¼" x ⅞"
65	18 x 11		
70	20 x 12		
75	20 x 12		
80	22 x 14		
85	22 x 14		
90	25 x 14		
95	25 x 11		
100	28 x 16		
110	28 x 16		
120	32 x 18		

Keyways for output hubs and bushes are machined in accordance with B.S. 4235/IS .2048 for metric shafts and B.S. 46 for inch shafts.

Keys are supplied with reduction bushes, but not where the output hubs directly fit the shaft.

Reduction bushes maybe supplied with two separate keys for hub and shaft or a single stepped key, depending on the bush wall thickness.

The shaft keyway should be machined to suit the standard key size shown below regardless of the hub bore diameter.

Optional Extras

- 1. Backstops:** A backstop may be incorporated on applications where it is necessary to prevent reversal of rotation. It is quickly installed within the Reducer by simply removing a cover plate.
- 2. Vertical Shafts:** Units suitable for mounting on vertical shafts can be supplied at extra charge. When ordering, please specify whether input shaft is upwards or downwards.
- 3. Reversing Duty:** Shaft Mounted Speed Reducers suitable for reversing duty can be supplied to order.
- 4. Flange Mounting:** The Speed Reducer casing design is such that the Reducer can be bolted direct to supporting framework. This may permit designers to omit a bearing or Plummer block but it does, of course, eliminate the easy belt adjustment feature characteristic of the shaft mounting version. See page 11-08 for dimensions.

Shaft Mounted Speed Reducer Plus Series

Dimensions - Shaft Mounting Sizes B, C, D, E, F, G, H & J

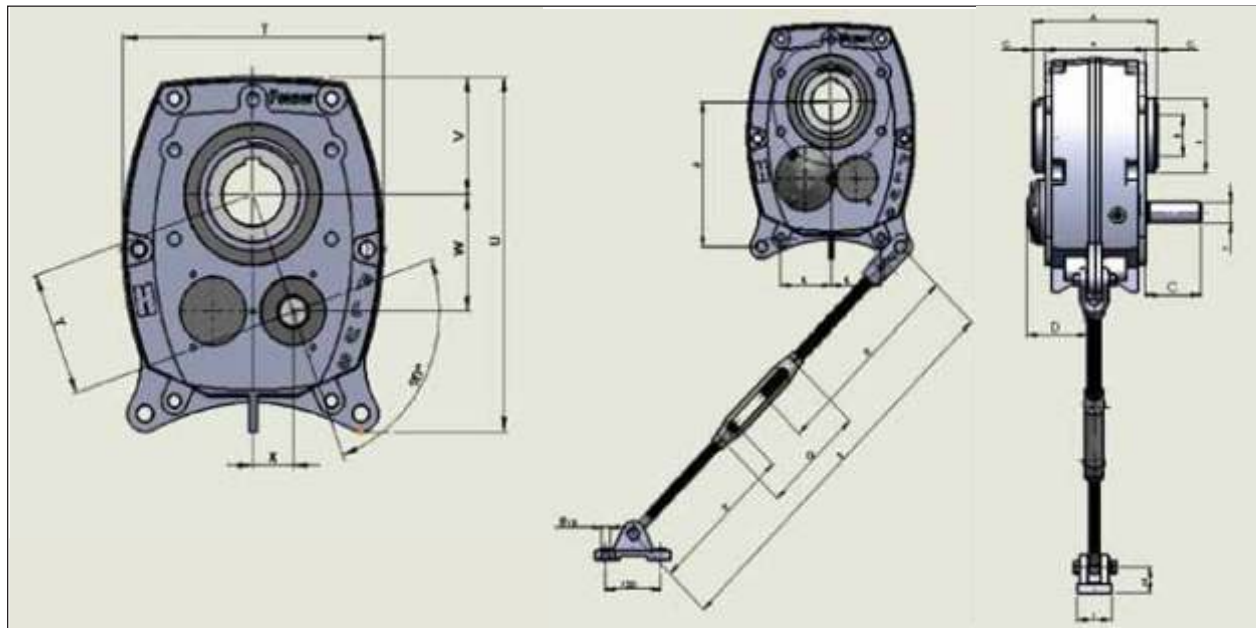

Table: 11-04

S i z e s	Approx. Mass Kg.		A	B	C	D	E	F	Input Shaft Keyway	G	H	J	K	L	M	N	O	P	Q	R	S*		T	U	V	W	X	Y
	Ratio 5	Ratios 13&20																			Min	Max						
	B	11.5																			12.5	124						
C	15	16	142	60	72	90	19 j6	6x3.5x50	12	118	142	75	24	20	65	5	10	200	300	600	750	186	236	82	75	25	79	
D	22	24	152	68	90	100	22 j6	6x3.5x56	12	127	172	82	28	24	75	5	12	216	350	700	850	217	282	97	90	31	95	
E	33	38	173	77	87	115	25 j6	8x4x63	19	136	188	76	28	24	75	5	12	216	350	700	850	261	336	120	110	37	116	
F	44	49	195	85	97	130	28 j6	8x4x70	20	155	222	90	34	30	100	6	16	216	375	750	900	287	386	128	126	44	133	
G	64	73.5	214	90	105	145	32 k6	10x5x70	20	174	249	102	34	50	100	6	16	216	375	660	900	320	422	141	141	50	150	
H	100	108	253	113	136	152	42 k6	12x5x96	24.5	204	294	152	70	50	120	18	16	222	375	750	900	365	477	158	156	56	166	
J	144	155	275	126	132	172	48 k6	14x5.5x96	30	215	353	145	70	50	120	18	16	222	375	750	900	433	570	192	189	62	200	

All dimensions are subject to alteration without notice.

All dimensions are in millimetres.

- Permits 150mm adjustments to tighten V-Belts. By cutting off threaded end of rods, 'S' may be reduced by up to 300mm on sizes B & C and 350mm on D & E and 395 mm on sizes F, G, H & J.

Keyways are British Standard and Indian Standard Metric.

Table: 11-04A
Exact Gear Ratios

Nominal Ratio	B	C	D	E	F	G	H	J
5	5.05	5.05	5.047	5.047	5.047	5.047	5.047	5.047
13	13.984	13.596	13.589	13.589	13.589	13.589	13.589	13.589
20	20.997	20.466	20.456	20.456	20.456	20.456	20.456	20.456



Shaft Mounted Speed Reducer Plus Series

Flange Mounting Sizes B, C, D, E, F, G, H & J

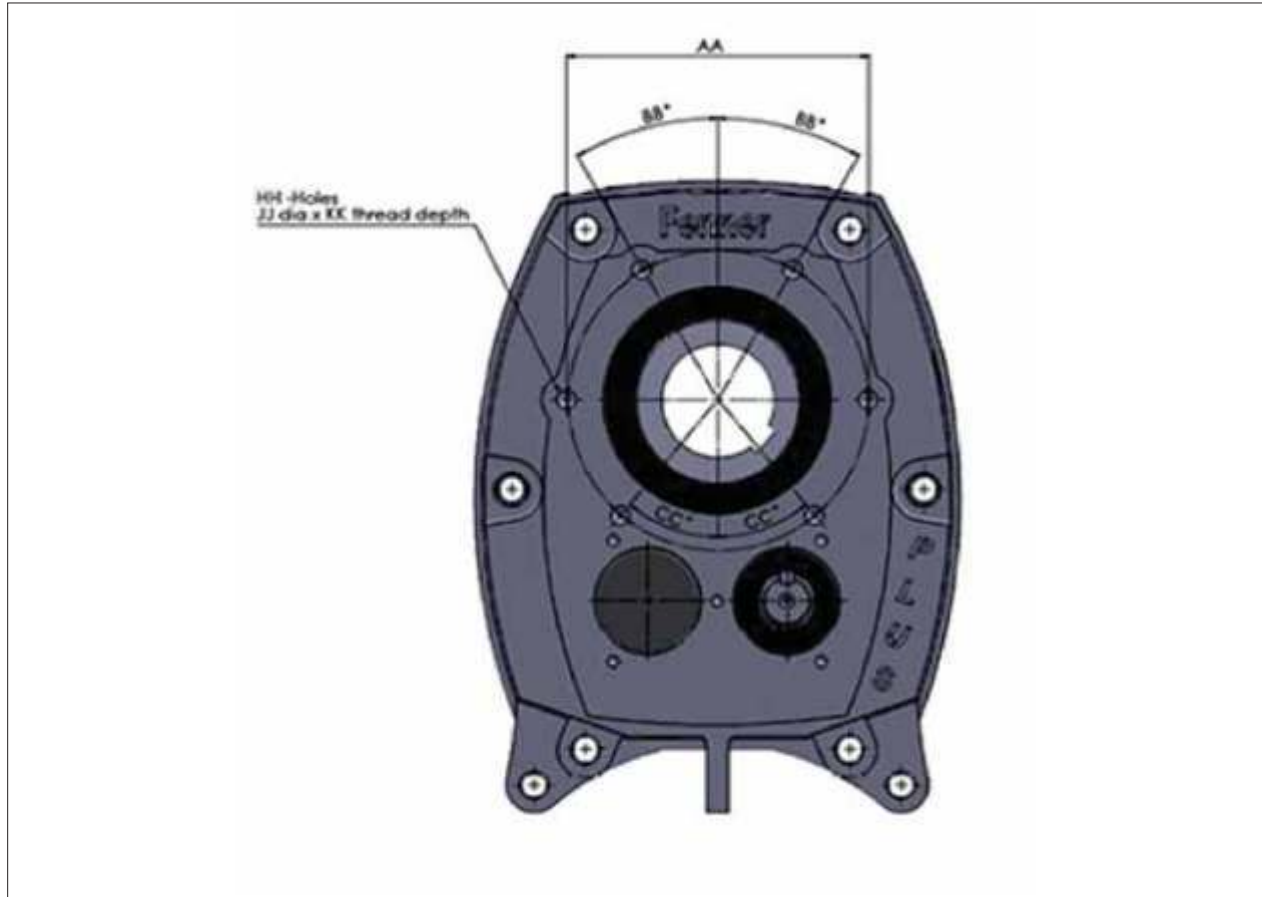

Table: 11-05 Flange Mounting Dimensions

Size	AA	BB	CC	HH	JJ	KK
B	106	45	45	4	M8	12
C	120	45	45	4	M10	15
D	135	30	40	6	M10	15
E	155	30	30	6	M10	15
F	175	42	30	6	M12	18
G	212	30	-	6	M16	22
H	250.6	61.4	61.4	5	M20	30
J	280	45	45	7	M20	30

All dimensions are subject to alteration without notice. Flange mounting holes may be drilled on either case half.

Shaft Mounted Speed Reducer Plus Series

Foot Mounting Sizes B, C, D, E, F, G, H & J

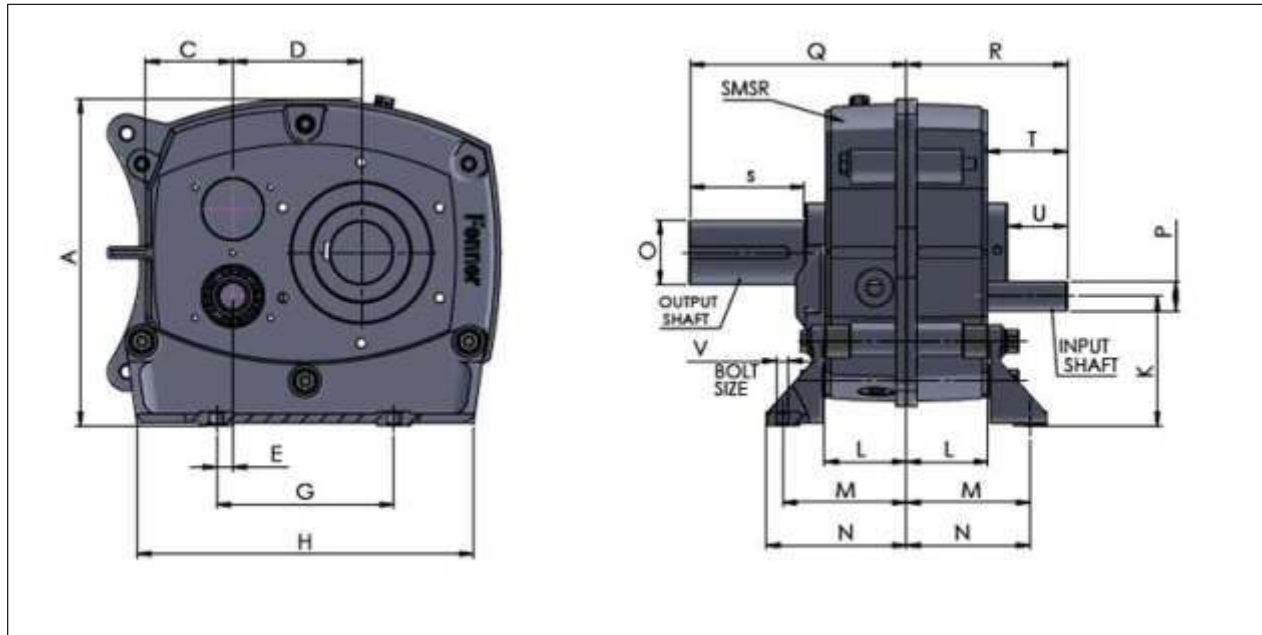

Table: 11-06 Foot Mounting Dimensions

DIMENSION	B	C	D	E	F	G	H	J
A	198	208	240	280	320	362	385	440
B	192	212	255	309	352	388	429	506
C	54	55	66	113	122	141	152	186
D	66	75	90	110	125	141	156	189
E	8	5	3	12	28	34	36	110
F	39	45	61	70	70	74	85	80
G	102	110	118	152	180	196	220	280
H	180	200	240	292	320	340	390	440
J	114	115	131	149	175	210	236	262
K	90	90	100	112	132	160	180	200
L	49	62	66	70	70	84	94	110
M	83	96	100	106	106	123	133	140
N	96	110	116	121	125	144	153	100
O	38 m6	45m6	50 m6	55 m6	60m6	75m6	90m6	100m6
P	14J6	19J6	22J6	25J6	28J6	32j6	42j6	48j6
Q	147	181	186	225	235	246	291	338
R	100	126	135	150	175	180	215	235
S	80	110	110	140	140	140	170	210
T	51	68	71	77	85	90	105	116
U	39	55	58	60	65	70	85	90
V	M8	M8	M10	M10	M12	M16	M16	M16

All dimensions are subject to alteration without notice. All dimensions are in millimeters.



Shaft Mounted Speed Reducer Plus Series

Motor Mounts - SMSR Plus

A motor mount is available which is designed to fit directly onto either the long edge or the short edge of the Shaft Mounted Speed Reducer.. For fitting of motor mounting onto the long edge of SMSR, CONSULT FENNER. The drive unit can then be located in any position around the shaft to permit easy belt tensioning.

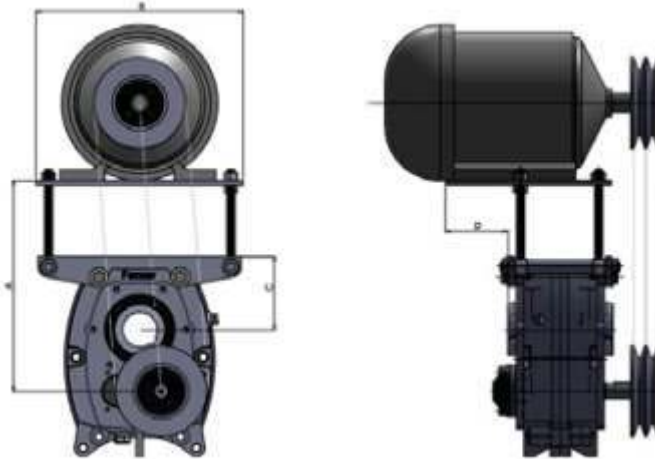

Table: 11- 07 Dimensions- Motor Mounting

Size	A		B	C	D	Accommodates Metric Motor Frame Size
	Min.	Max.				
B	174	229	244	77	86	63, 71, 80, 90S, 90L
C	200	253	272	88	86	63, 71, 80, 90S, 90L, 100L
D	236	291	300	106	90	71, 80, 90S, 90L, 100L, 112M
E	286	339	340	138	143	80, 90S, 90L, 100L, 112M
F	304	376	340	135	133	80, 90S, 90L, 100L, 112M, 132S, 132M,
G	342	412	415	158	210	90S, 90L, 100L, 112M, 132S, 132M, 160M, 160L,
H	388	456	450	169	218	90L, 100L, 112M, 132S, 132M, 160M, 160L, 180M, 180L
J	503	586	505	209	255	100L, 112M, 132S, 132M, 160M, 160L, 180M, 200L

All dimensions are subject to alteration without notice

All dimensions are in millimeters. For dimensions of basic Reducer see page 11-05. It is recommended that larger frame size motors than those listed for a particular size SMSR should be mounted independently.

'A Max' must include belt tensioning allowances, 'A Min' must include belt fitting allowances.

The Fenner motor mounting assembly provides a rigid base plate which is designed to accommodate a wide range of motor frame sizes.

Each size of motor mount has sufficient adjustment available to ensure that a standard belt can be fitted and re-tensioned as required throughout its working life than 'A' max in the dimension table.

To determine optimum belt length when using a motor mount, first calculate the minimum centre distance as follows :

$$'X \text{ Min}' = \text{Motor Frame Size} + 'A \text{ Min}' + \text{Installation Allowance.}$$

A belt length should be selected from the Fenner Wedge

Belt Drives catalogue which gives a centre distance equal to or slightly larger than the 'X Min' value determined above.

To check that sufficient adjustment is still available for re-tensioning, multiply the actual drive centre distance by 1.01 and subtract the motor frame size. The resulting value should be less than 'A Max' in the dimension table.

Belt Installation Allowance

SPZ	20 mm
SPA	25 mm
SPB	30 mm
SPC	50 mm

Shaft Mounted Speed Reducer Plus Series

Lubrication - SMSR Plus

IMPORTANT: The Shaft Mounted Speed Reducers are despatched without oil. They must be filled as instructed before running. Use high grade oil as shown on lubrication chart supplied attached to breather plug or alternative grades stated below. Fill to level plug when Reducer is not running. Drain, flush and refill every six months of operation. Check oil level regularly. Positions of filler, breather and drain plug for different mounting positions are shown in Fig. below.

Normal operating positions are shown in Fig. below. Note that the Reducer is supplied with four plugs. After the Reducer has been mounted in its running position the plugs must be located as shown in Fig. below for the appropriate mounting position.

If the Reducer is not within 20° of one of the positions shown, the oil level plug cannot be safely used to check the oil level. This can be overcome by disconnecting the torque-arm and swinging the Reducer around to one of the positions shown.

Because of the many positions of the Reducer it may be necessary or desirable to make special adaptations using the plug holes in the Reducer with standard pipe fittings or oil level gauges.

CAUTION

Too much oil will cause over-heating. Too little oil will cause gear failure.

Mounting Positions

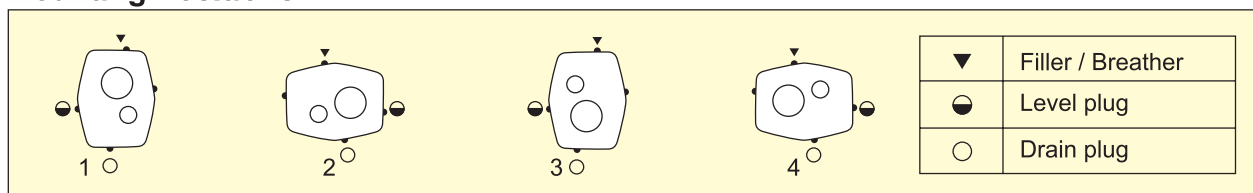

Table: 11- 08 Recommended Lubricants

	Ambient Temp °C	13 : 1 and 20 : 1 RATIO GEARBOXES			5 : 1 RATIO GEARBOX			
		0 - 20 rev / min	21 -50 rev / min	51 - 120 rev / min	0 - 100 rev / min	101 - 200 rev / min	201 - 400 rev / min	
		BCDEFGHJ	BCDEFGHJ	BCDEFGHJ	BCDEFGHJ	BCDEFGHJ	BC	DEFGHJ
Bharat Petroleum (Amocam)	- 10 to + 5	220	220	150	100	100	100	68
	6 to 25	460	460	320	460	320	320	220
	26 to 40	680	680	680	800	680	680	460
Indian Oil (Servomesh)	- 10 to + 5	SP 68	SP 68	SP 68	SP 100	SP 100	SP 100	SP 68
	6 to 25	SP 220	SP 150	SP 100	SP 460	SP 320	SP 320	SP 220
	26 to 40	SP 460	SP 320	SP 320	SP 800	SP 680	SP 680	SP 460

Table: 11- 09 Mounting position - Oil Quantities (litres)

Unit Size	Approximate Capacity - Litres							
	20 : 1 & 13 : 1				5 : 1			
	1	2	3	4	1	2	3	4
B	0.25	0.4	0.3	0.4	0.3	0.3	0.3	0.4
C	0.4	0.6	0.5	0.6	0.5	0.5	0.5	0.6
D	0.7	0.9	0.8	0.9	0.8	0.9	0.8	1.0
E	1.0	1.8	1.4	1.6	1.2	1.7	1.4	1.8
F	2.3	2.6	2.4	2.2	2.5	2.6	2.4	2.5
G	3.0	3.2	3.2	3.3	3.2	3.2	3.2	3.3
H	3.8	5.5	4.2	5.1	4.1	5.3	4.1	5.8
J	5.4	8.5	5.9	8.3	5.7	8.6	5.9	8.6

Capacities shown are approximate



Shaft Mounted Speed Reducer Plus Series

**Table: 11- 09 Power Ratings (kW)
Ratio 5:1 UNITS**

Output Rev./ Min.	B05	C05	D05	E05	F05	G05	H05	J05
100	2.56	4.41	6.91	10.78	15.76	27.50	39.44	63.18
110	2.74	4.62	7.24	11.25	16.21	29.35	41.35	66.17
120	2.99	4.82	7.55	11.95	17.10	29.50	43.17	69.15
130	3.21	5.03	7.88	12.12	17.62	31.21	44.98	72.04
140	3.40	5.24	8.20	12.97	18.85	33.52	46.89	75.02
150	3.46	5.44	8.53	13.25	19.32	34.25	48.71	78.01
160	3.56	5.65	8.85	13.92	20.52	34.97	50.52	80.89
170	3.66	5.85	9.17	14.27	21.90	37.20	52.43	83.88
180	3.76	6.06	9.49	14.80	22.12	38.23	54.24	86.86
190	3.86	6.27	9.82	15.42	22.24	39.26	56.06	89.75
200	4.01	6.47	10.14	15.87	23.40	40.82	57.87	92.73
210	4.12	6.69	10.46	16.82	24.12	41.22	59.78	95.72
220	4.21	6.89	10.78	17.20	24.75	42.95	61.60	98.60
230	4.33	7.10	11.11	17.88	24.92	44.76	63.41	101.59
240	4.45	7.30	11.43	18.27	26.45	45.84	65.32	104.48
250	4.56	7.51	11.76	18.50	27.20	47.27	67.14	107.46
260	4.67	7.72	12.07	19.12	28.92	48.92	68.95	110.45
270	4.81	7.92	12.40	19.75	29.12	50.02	70.77	113.33
280	4.97	8.13	12.72	20.12	29.34	51.32	72.68	115.32
290	5.12	8.33	13.05	20.75	30.02	52.76	74.49	
300	5.21	8.54	11.76	21.27	31.10	53.87	76.30	
310	5.37	8.74	12.07	21.96	31.62	55.76	78.21	
320	5.52	8.95	12.40	22.27	32.54	56.92	80.03	
330	5.62	9.16	12.72	23.13	33.20	57.77		
340	5.82	9.36	13.05	23.75	34.35	58.95		
350	6.02	9.57	14.97	24.17	35.07	60.45		
360	6.12	9.77	15.30	24.82	35.82	61.76		
370	6.32	9.98	15.62	25.16	36.75	63.07		
380	6.42	10.18	15.95	25.71	37.68			
390	6.62	10.39	16.27	26.20	38.61			
400	6.82	10.60	16.59	26.70	39.54			
Torque at 100 rev/min Nm	244	421	650	1030	1505	2626	3766	6034

**Power Ratings (kW)
Ratio 13 & 20:1 UNITS**

Output Rev./ Min.	B13 B20	C13 C20	D13 D20	E13 E20	F13 F20	G13 G20	H13 H20	J13 J20
10	0.28	0.52	0.81	1.27	1.90	3.22	4.64	7.32
12	0.34	0.64	0.99	1.52	2.35	3.95	5.70	8.97
14	0.40	0.75	1.18	1.76	2.73	4.76	6.75	10.63
16	0.45	0.87	1.37	2.14	3.12	5.52	7.80	12.29
18	0.51	0.99	1.55	2.45	3.65	6.34	8.85	13.85
20	0.56	1.11	1.74	2.72	4.05	7.11	9.90	15.50
22	0.60	1.22	1.92	3.02	4.50	7.75	10.95	17.16
24	0.66	1.35	2.10	3.27	4.95	8.62	12.00	18.82
26	0.72	1.46	2.28	3.45	5.35	9.34	13.06	20.48
28	0.77	1.58	2.47	3.97	5.72	10.11	14.11	22.13
30	0.82	1.70	2.65	4.12	6.10	10.97	15.17	23.79
32	0.88	1.80	2.84	4.36	6.72	11.72	16.22	25.45
34	0.94	1.93	3.03	4.72	7.11	12.45	17.27	27.11
36	0.99	1.99	3.11	4.97	7.30	12.65	17.79	27.93
38	1.05	2.05	3.21	5.10	7.42	13.21	18.32	28.76
40	1.11	2.17	3.39	5.47	8.02	13.97	19.38	30.42
42	1.15	2.28	3.57	5.65	8.45	14.72	20.43	32.08
44	1.19	2.34	3.67	5.97	8.76	15.02	20.95	32.91
46	1.24	2.40	3.76	6.10	8.95	15.42	21.48	33.74
48	1.30	2.46	3.85	6.22	9.10	15.98	22.00	34.56
50	1.36	2.52	3.94	6.37	9.35	16.25	22.53	35.39
52	1.40	2.64	4.13	6.62	9.72	16.92	23.58	36.95
54	1.45	2.75	4.32	6.96	10.15	17.72	24.63	38.61
56	1.51	2.81	4.41	7.12	10.42	18.17	25.15	39.20
58	1.57	2.87	4.50	7.27	10.75	18.56	25.68	40.27
60	1.62	2.93	4.59	7.35	10.82	18.92	26.21	41.10
62	1.68	2.99	4.68	7.42	11.05	19.38	26.74	41.93
64	1.73	3.05	4.77	7.67	11.24	19.57	27.27	42.75
66	1.78	3.10	4.86	7.82	11.35	20.12	27.79	43.58
68	1.82	3.17	4.96	7.97	11.62	20.45	28.32	44.41
70	1.87	3.23	5.05	8.10	11.92	20.88	28.84	45.24
72	1.92	3.29	5.14	8.25	12.17	21.34	29.24	46.07
74	1.97	3.34	5.23	8.46	12.43	21.56	29.89	46.90
76	2.01	3.45	5.40	8.57	12.88	22.34	30.85	48.41
78	2.05	3.55	5.57	8.92	13.27	22.95	31.81	49.92
80	2.13	3.77	5.90	9.57	14.02	24.45	33.73	52.94
85	2.23	3.98	6.25	10.12	14.85	25.82	35.65	55.97
90	2.37	4.20	6.58	10.67	15.64	27.12	37.57	58.99
95	2.49	4.31	6.75	10.90	16.06	27.89	38.68	61.91
100	2.61	4.41	6.91	11.12	16.47	28.65	39.49	
Torque at 10 rev/min Nm	265	495	775	1212	1815	3075	4431	6995

The dotted line shows the limit of recommended output speed for reducer with ratio 20:1
For higher speed use 13:1 or 5:1 reducer

Shaft Mounted Speed Reducer Plus Series

Table: 11-10 Belt Drives-1440 Rev/Min Motor

B 5 : 1

C 5 : 1

Output Speed Rev/Min	Pulley Ratio	Pulley Dia (mm)		Number of Belts	Output Speed Rev/Min	Pulley Ratio	Pulley Dia (mm)		Number of Belts
		Motor	Gearbox				Motor	Gearbox	
51	5.63	71	400	1SPZ*	51	5.63	71	400	2SPZ
57	5.00	80	400	1SPZ*	61	4.70	67	315	2SPZ
64	4.44	90	400	1SPZ*	64	4.44	71	315	2SPZ
71	4.00	100	400	1SPZ*	71	4.00	100	400	1SPA*
80	3.57	112	400	1SPZ*	76	3.77	106	400	1SPA*
86	3.32	95	315	1SPZ*	80	3.57	112	400	1SPZ
91	3.15	100	315	1SPZ*	86	3.33	75	250	3SPZ
97	2.94	85	250	2SPZ	89	3.20	125	400	1SPZ
101	2.82	71	200	2SPZ	94	3.03	132	400	1SPA*
107	2.67	75	200	2SPZ	100	2.86	140	400	1SPZ
113	2.54	71	180	2SPZ	107	2.67	118	315	1SPA*
119	2.40	75	180	2SPZ	113	2.52	125	315	1SPA*
128	2.23	112	250	1SPZ*	120	2.39	132	315	1SPA*
134	2.13	75	160	2SPZ	127	2.25	80	180	3SPZ
137	2.09	67	140	3SPZ	134	2.13	75	160	3SPZ
145	1.97	71	140	3SPZ	143	2.00	100	200	2SPZ
151	1.89	106	200	1SPZ*	151	1.89	132	250	1SPA*
160	1.79	112	200	1SPA*	160	1.79	140	250	1SPA*
168	1.70	106	180	1SPA*	168	1.70	106	180	2SPA
171	1.67	67	112	3SPZ	171	1.67	150	250	1SPA*
177	1.61	112	180	2SPZ	177	1.61	112	180	2SPZ
181	1.58	71	112	3SPZ	178	1.60	125	200	1SPA*
187	1.53	118	180	1SPA*	187	1.53	118	180	2SPA
190	1.50	100	150	2SPA	190	1.50	100	150	2SPA
200	1.43	112	160	1SPA*	200	1.43	140	200	1SPA*
205	1.39	90	125	2SPZ	205	1.39	90	125	3SPZ
210	1.36	118	160	1SPA*	209	1.36	132	180	2SPA
216	1.32	106	140	2SPA	214	1.33	150	200	1SPA
222	1.29	140	180	1SPZ*	222	1.29	140	180	2SPZ
228	1.25	112	140	1SPA*	223	1.28	125	160	1SPA*
235	1.21	132	160	1SPA*	235	1.21	132	160	2SPA
242	1.18	95	112	2SPZ	242	1.18	106	125	2SPA
250	1.14	140	160	1SPA*	250	1.14	140	160	2SPZ
256	1.12	112	125	1SPA*	254	1.12	80	90	4SPZ
266	1.07	140	150	1SPA*	257	1.11	180	200	1SPA*
270	1.06	90	95	3SPZ	269	1.06	118	125	2SPA
285	1.00	100	100	2SPZ	285	1.00	100	100	3SPZ
302	1.06	90	85	3SPZ	300	1.05	118	112	2SPA
306	1.07	150	140	1SPA*	306	1.07	150	140	2SPA
319	1.12	140	125	1SPA*	317	1.11	200	180	1SPA*
324	1.14	150	132	1SPA*	326	1.14	160	140	2SPZ
336	1.18	100	85	3SPZ	336	1.18	100	85	4SPZ
342	1.20	180	150	1SPA*	338	1.19	140	118	2SPA
355	1.24	112	90	3SPZ	342	1.20	150	125	2SPA
362	1.27	150	118	1SPZ*	355	1.24	112	90	4SPZ
365	1.28	160	125	2SPZ	363	1.27	150	118	2SPA
376	1.32	112	85	3SPZ	367	1.29	180	140	2SPZ
380	1.33	200	150	1SPA*	375	1.32	125	95	3SPZ
387	1.36	160	118	2SPA	387	1.36	160	118	2SPA
396	1.39	125	90	3SPZ	396	1.39	250	180	1SPA*

**Whilst one belt is adequate for power transmission, two belts can be used without overloading the gearbox bearings. For other speeds, consult Fenner.*



Shaft Mounted Speed Reducer Plus Series

Table: 11-11 Belt Drives-1440 Rev/Min Motor

D 5 : 1

E 5 : 1

Output Speed Rev/Min	Pulley Ratio	Pulley Dia (mm)		Number of Belts	Output Speed Rev/Min	Pulley Ratio	Pulley Dia (mm)		Number of Belts
		Motor	Gearbox				Motor	Gearbox	
51	5.62	112	630	1SPA*	51	5.56	90	500	3SPZ
54	5.26	95	500	2SPZ	54	5.26	95	500	3SPZ
60	4.77	132	630	1SPA*	60	4.77	132	630	2SPA
64	4.46	112	500	1SPA*	63	4.50	140	630	1SPA*
67	4.24	118	500	1SPA*	68	4.20	150	630	1SPA*
75	3.79	132	500	1SPA*	73	3.94	160	630	1SPA*
82	3.50	90	315	3SPZ	80	3.57	112	400	2SPA
86	3.32	95	315	3SPZ	84	3.39	118	400	2SPA
91	3.15	100	315	2SPA	89	3.20	125	400	2SPA
101	2.81	112	315	2SPZ	96	2.97	106	315	3SPA
107	2.67	150	400	1SPA*	101	2.81	112	315	3SPZ
113	2.52	125	315	2SPZ	107	2.67	150	400	2SPA
120	2.39	132	315	2SPA	113	2.52	125	315	3SPZ
128	2.23	112	250	2SPA	120	2.39	132	315	2SPA
135	2.12	118	250	2SPA	127	2.25	140	315	2SPA
143	2.00	100	200	3SPZ	136	2.11	95	200	5SPZ
151	1.89	106	200	3SPA	143	2.00	100	200	4SPA
159	1.80	100	180	3SPZ	151	1.89	95	180	5SPZ
163	1.75	180	315	1SPA*	160	1.79	112	200	4SPZ
171	1.67	150	250	2SPA	168	1.70	106	180	4SPA
178	1.61	112	180	3SPZ	173	1.65	170	280	2SPB
181	1.57	200	315	1SPA*	178	1.60	125	200	3SPA
187	1.53	118	180	2SPA	183	1.56	160	250	2SPA
190	1.50	100	150	3SPA	189	1.51	106	160	4SPA
200	1.43	112	160	3SPZ	198	1.44	125	180	4SPZ
204	1.40	100	140	3SPA	204	1.40	160	224	2SPB
209	1.36	132	180	2SPA	209	1.36	132	180	3SPA
216	1.32	106	140	3SPA	214	1.33	150	200	3SPA
222	1.29	140	180	2SPA	223	1.28	125	160	3SPA
228	1.25	112	140	3SPZ	228	1.25	200	250	2SPA
235	1.21	132	160	2SPA	235	1.21	132	160	3SPA
242	1.18	106	125	3SPA	240	1.19	118	140	4SPA
250	1.14	140	160	2SPA	250	1.14	140	160	4SPZ
255	1.12	100	112	4SPZ	254	1.12	160	180	2SPB
266	1.07	140	150	2SPA	257	1.11	180	200	2SPA
269	1.06	118	125	3SPA	266	1.07	140	150	3SPA
285	1.00	140	140	2SPA	270	1.06	125	132	4SPA
301	1.05	118	112	3SPA	285	1.00	125	125	5SPZ
306	1.07	150	140	2SPA	301	1.05	118	112	5SPA
317	1.11	100	90	5SPZ	304	1.07	160	150	3SPA
324	1.14	150	132	3SPA	317	1.11	200	180	2SPA
337	1.18	200	170	2SPB	324	1.14	150	132	4SPA
342	1.20	180	150	2SPA	336	1.18	200	170	2SPB
346	1.21	160	132	3SPA	342	1.20	180	150	2SPA
356	1.25	250	200	1SPA*	356	1.25	212	170	2SPB
365	1.28	160	125	3SPZ	365	1.28	160	125	5SPZ
375	1.32	125	95	5SPZ	376	1.32	224	170	2SPB
380	1.33	200	150	2SPA	380	1.33	200	150	3SPA
387	1.36	160	118	3SPA	387	1.36	160	118	4SPA
396	1.39	125	90	5SPZ	396	1.39	250	180	2SPA

*Whilst one belt is adequate for power transmission, two belts can be used without overloading the gearbox bearings. For other speeds, consult Fenner.

Shaft Mounted Speed Reducer Plus Series

Table: 11-12 Belt Drives-1440 Rev/Min Motor

F 5 : 1

Output Speed Rev/Min	Pulley Ratio	Pulley Dia (mm)		Number of Belts
		Motor	Gearbox	
50	5.71	140	800	3SPZ
57	5.00	100	500	3SPA
61	4.72	106	500	3SPA
68	4.21	95	400	5SPZ
73	3.94	160	630	2SPA
77	3.71	170	630	2SPB
82	3.50	180	630	2SPB
86	3.32	95	315	6SPZ
91	3.15	100	315	5SPZ
97	2.94	170	500	2SPB
103	2.78	180	500	2SPA
108	2.63	190	500	2SPB
113	2.52	125	315	4SPZ
121	2.35	170	400	2SPB
127	2.25	140	315	4SPZ
135	2.12	118	250	4SPA
143	2.00	125	250	5SPZ
151	1.89	132	250	4SPA
160	1.79	140	250	5SPZ
168	1.69	118	200	5SPA
173	1.65	170	280	2SPB
178	1.60	125	200	4SPA
181	1.56	160	250	2SPB
187	1.53	118	180	5SPA
192	1.49	212	315	2SPB
200	1.43	140	200	5SPZ
205	1.39	180	250	2SPB
215	1.32	160	212	3SPB
222	1.29	140	180	4SPA
226	1.26	250	315	2SPB
235	1.21	132	160	5SPA
242	1.18	190	224	2SPB
250	1.14	140	160	6SPZ
255	1.12	200	224	2SPB
267	1.07	150	160	4SPA
271	1.05	224	236	2SPB
285	1.00	224	224	2SPB
301	1.06	224	212	2SPB
304	1.07	160	150	4SPA
317	1.11	200	180	3SPA
324	1.14	150	132	5SPA
336	1.18	200	170	3SPB
342	1.20	180	150	4SPA
356	1.25	212	170	3SPB
360	1.26	315	250	2SPB
365	1.28	160	125	6SPA
376	1.32	224	170	3SPB
380	1.33	200	150	4SPA
387	1.36	160	118	6SPA
396	1.39	250	180	3SPA

G 5 : 1

Output Speed Rev/Min	Pulley Ratio	Pulley Dia (mm)		Number of Belts
		Motor	Gearbox	
51	5.62	112	630	3SPA
54	5.26	95	500	5SPZ
60	4.77	132	630	3SPA
63	4.50	140	630	4SPZ
67	4.24	118	500	4SPA
71	4.00	125	500	5SPZ
77	3.71	170	630	2SPB
84	3.39	118	400	5SPA
89	3.20	125	400	6SPZ
94	3.03	132	400	4SPA
101	2.81	224	630	2SPB
107	2.67	150	400	4SPA
114	2.50	160	400	2SPB
121	2.36	212	500	2SPB
127	2.25	140	315	5SPA
136	2.10	150	315	5SPA
143	2.00	200	400	3SPA
151	1.89	212	400	3SPB
160	1.79	140	250	6SPA
163	1.75	180	315	3SPB
168	1.69	236	400	2SPB
172	1.66	190	315	3SPB
178	1.60	250	400	2SPB
183	1.56	180	280	3SPB
190	1.50	236	355	3SPB
192	1.49	212	315	3SPB
200	1.43	140	200	6SPA
206	1.39	170	236	4SPB
214	1.33	150	200	6SPA
225	1.27	280	355	2SPB
228	1.25	200	250	3SPB
238	1.20	250	300	3SPC
242	1.18	200	236	3SPB
252	1.13	265	300	3SPC
256	1.11	212	236	3SPB
266	1.07	280	300	3SPC
270	1.06	212	224	3SPB
285	1.00	224	224	3SPB
301	1.05	236	224	3SPB
306	1.07	300	280	3SPC
317	1.11	200	180	4SPB
322	1.13	355	315	2SPB
336	1.18	200	170	5SPB
341	1.20	335	280	3SPC
355	1.24	224	180	4SPB
359	1.26	315	250	2SPB
374	1.31	315	180	4SPB
381	1.33	250	236	3SPB
396	1.39	224	180	5SPA
399	1.40	224	160	5SPB

**Whilst one belt is adequate for power transmission, two belts can be used without overloading the gearbox bearings. For other speeds, consult Fenner.*



Shaft Mounted Speed Reducer Plus Series

Table: 11-13 Belt Drives-1440 Rev/min Motor

H 5 : 1

Output Speed Rev/Min	Pulley Ratio	Pulley Dia (mm)		Number of Belts
		Motor	Gearbox	
50	5.71	140	800	5SPZ
54	5.26	190	1000	3SPB
60	4.77	132	630	5SPA
63	4.50	140	630	4SPA
71	4.00	200	800	3SPA
82	3.50	180	630	3SPA
86	3.32	190	630	3SPB
91	3.15	200	630	3SPA
96	2.97	212	630	3SPB
101	2.81	224	630	3SPB
107	2.67	150	400	6SPA
113	2.52	250	630	2SPB
121	2.35	170	400	4SPB
127	2.25	280	630	2SPB
136	2.11	190	400	4SPB
142	2.01	236	475	3SPC
145	1.97	160	315	6SPA
150	1.91	236	450	3SPC
160	1.79	224	400	3SPB
163	1.75	180	315	4SPB
168	1.69	236	400	3SPB
172	1.66	190	315	4SPB
178	1.60	265	425	3SPC
181	1.57	200	315	5SPA
188	1.52	280	425	3SPC
192	1.49	212	315	4SPB
200	1.43	280	400	3SPB
211	1.35	315	425	3SPC
216	1.32	212	280	4SPB
225	1.27	315	400	2SPB
228	1.25	224	280	3SPC
238	1.20	250	300	3SPC
242	1.18	212	250	4SPB
252	1.13	265	300	3SPC
256	1.11	212	236	5SPB
266	1.07	280	300	3SPC
271	1.05	224	236	4SPB
285	1.00	200	200	5SPB
300	1.05	315	300	3SPC
306	1.07	300	280	3SPC
317	1.11	200	180	6SPB
323	1.13	300	265	3SPC
336	1.18	212	180	6SPB
341	1.20	335	280	3SPC
357	1.25	250	200	6SPA
362	1.27	355	280	3SPB
375	1.32	250	190	5SPB
381	1.33	315	236	3SPC
396	1.39	250	180	6SPB
399	1.40	280	200	5SPB

J 5 : 1

Output Speed Rev/Min	Pulley Ratio	Pulley Dia (mm)		Number of Belts
		Motor	Gearbox	
51	5.56	180	1000	3SPB
54	5.26	190	1000	3SPB
57	5.00	160	800	4SPB
61	4.71	170	800	4SPB
63	4.50	140	630	6SPA
68	4.21	190	800	4SPB
71	4.00	200	800	5SPA
76	3.77	212	800	4SPB
80	3.57	224	800	3SPB
84	3.39	236	800	3SPB
89	3.20	250	800	3SPB
96	2.97	212	630	4SPB
100	2.86	280	800	3SPB
107	2.67	236	630	4SPB
112	2.54	315	800	3SPB
120	2.38	265	630	3SPC
127	2.24	250	560	3SPC
134	2.13	375	800	3SPC
143	2.00	250	500	4SPB
150	1.90	250	475	3SPC
159	1.79	265	475	3SPC
168	1.70	280	475	3SPC
171	1.67	300	500	3SPC
178	1.60	265	425	3SPC
181	1.57	400	630	3SPC
189	1.51	315	475	3SPC
201	1.42	250	355	4SPC
203	1.41	355	500	3SPC
211	1.35	315	425	3SPC
215	1.32	400	530	3SPC
225	1.27	315	400	4SPB
228	1.25	300	375	3SPC
238	1.20	375	450	3SPC
241	1.18	300	355	3SPC
252	1.13	265	300	4SPC
255	1.12	335	375	3SPC
266	1.07	280	300	4SPC
269	1.06	335	355	3SPC
285	1.00	280	280	4SPC
300	1.05	315	300	4SPC
302	1.06	355	335	3SPC
306	1.07	300	280	4SPC
319	1.12	375	335	3SPC
338	1.18	355	300	4SPC
341	1.19	400	335	3SPC
357	1.25	375	300	4SPC
360	1.26	315	250	5SPC
362	1.27	400	315	3SPC
381	1.33	315	236	5SPC
382	1.34	355	265	4SPC

**Whilst one belt is adequate for power transmission, two belts can be used without overloading the gearbox bearings. For other speeds, consult Fenner.*

Shaft Mounted Speed Reducer Plus Series

Table: 11-14 Belt Drives-1440 Rev/min Motor

B 13 : 1

B 20 : 1

Output Speed Rev/Min	Pulley Ratio	Pulley Dia (mm)		Number of Belts	Output Speed Rev/Min	Pulley Ratio	Pulley Dia (mm)		Number of Belts
		Motor	Gearbox				Motor	Gearbox	
17	5.97	67	400	1SPZ*	10	6.67	75	500	2SPZ
22	4.70	67	315	1SPZ*	11	6.25	80	500	2SPZ
24	4.20	75	315	1SPZ*	12	5.97	67	400	1SPZ*
28	3.73	67	250	1SPZ*	13	5.26	95	500	2SPZ
31	3.33	75	250	1SPZ*	14	5.00	80	400	1SPZ*
34	2.99	67	200	1SPZ*	15	4.70	67	315	1SPZ*
36	2.82	71	200	1SPZ*	16	4.20	75	315	1SPZ*
38	2.69	67	180	1SPZ*	17	3.94	80	315	1SPZ*
41	2.54	71	180	1SPZ*	18	3.73	67	250	1SPZ*
43	2.39	67	160	1SPZ*	19	3.57	112	400	1SPZ*
46	2.25	71	160	1SPZ*	20	3.52	71	250	1SPZ*
48	2.13	75	160	1SPZ*	21	3.33	75	250	1SPZ*
51	2.00	80	160	1SPZ*	22	3.12	80	250	1SPZ*
55	1.88	85	160	1SPZ*	23	2.99	67	200	1SPZ*
59	1.75	80	140	1SPZ*	24	2.82	71	200	1SPZ*
62	1.65	85	140	1SPZ*	25	2.78	90	250	1SPZ*
64	1.60	100	160	1SPZ*	26	2.69	67	180	1SPZ*
66	1.56	90	140	1SPZ*	27	2.54	71	180	1SPZ*
70	1.47	85	125	1SPZ*	29	2.39	67	160	1SPZ*
74	1.39	90	125	1SPZ*	30	2.25	71	160	1SPZ*
78	1.32	95	125	1SPZ*	32	2.13	75	160	1SPZ*
82	1.25	100	125	1SPZ*	33	2.09	67	140	1SPZ*
86	1.20	71	85	2SPZ	34	2.00	80	160	1SPZ*
91	1.13	71	80	2SPZ	35	1.97	71	140	1SPZ*
97	1.06	100	106	1SPA*	37	1.87	67	125	1SPZ*
103	1.00	106	106	1SPA*	39	1.76	71	125	1SPZ*
109	1.06	112	106	1SPA*	40	1.70	106	180	1SPA*
115	1.12	125	112	1SPZ*	41	1.67	67	112	1SPZ*
117	1.13	85	75	2SPZ	43	1.58	71	112	1SPZ*
121	1.18	125	106	1SPA*	44	1.56	90	140	1SPZ*
123	1.20	90	75	2SPZ	45	1.53	118	180	1SPA*
125	1.21	160	132	1SPA*	46	1.49	67	100	1SPZ*
129	1.25	140	112	1SPZ*	47	1.47	85	125	1SPZ*
130	1.27	95	75	2SPZ	48	1.42	67	95	1SPZ*
132	1.29	180	140	1SPA*	49	1.39	90	125	1SPZ*
136	1.32	140	106	1SPA*	50	1.36	132	180	1SPA*
140	1.36	180	132	1SPA*	51	1.34	71	95	1SPZ*
143	1.39	125	90	2SPZ	52	1.32	85	112	1SPZ*
146	1.42	150	106	1SPA*	54	1.27	71	90	1SPZ*
148	1.44	180	125	1SPA*	55	1.24	90	112	1SPZ*
151	1.47	125	85	2SPZ	57	1.20	75	90	1SPZ*
154	1.49	112	75	2SPZ	58	1.18	85	100	1SPZ*
155	1.51	160	106	1SPA*	61	1.13	75	85	1SPZ*
157	1.53	180	118	1SPA*	62	1.11	90	100	1SPZ*
161	1.56	125	80	2SPZ	64	1.07	140	150	1SPA*
165	1.61	180	112	1SPA*	65	1.06	80	85	1SPZ*
170	1.65	140	85	2SPZ	69	1.00	80	80	1SPZ*
172	1.67	125	75	2SPZ	72	1.05	100	95	1SPZ*
175	1.70	180	106	1SPA*	73	1.07	80	75	2SPZ
180	1.75	140	80	2SPZ	76	1.11	100	90	1SPZ*

**Whilst one belt is adequate for power transmission, two belts can be used without overloading the gearbox bearings. For other speeds, consult Fenner.*



Shaft Mounted Speed Reducer Plus Series

Table: 11-15 Belt Drives-1440 Rev/min Motor

C 13 : 1

C 20 : 1

Output Speed Rev/Min	Pulley Ratio	Pulley Dia (mm)		Number of Belts	Output Speed Rev/Min	Pulley Ratio	Pulley Dia (mm)		Number of Belts
		Motor	Gearbox				Motor	Gearbox	
18	5.97	67	400	1SPZ*	10	7.04	71	500	2SPZ
21	5.00	80	400	1SPZ*	11	6.25	80	500	2SPZ
25	4.20	75	315	1SPZ*	12	5.97	67	400	1SPZ*
27	3.94	80	315	1SPZ*	13	5.63	71	400	2SPZ
30	3.52	71	250	1SPZ*	15	4.70	67	315	1SPZ*
34	3.12	80	250	1SPZ*	16	4.44	71	315	1SPZ*
36	2.94	85	250	1SPZ*	17	4.20	75	315	1SPZ*
38	2.78	90	250	1SPZ*	18	3.94	80	315	1SPZ*
40	2.63	95	250	1SPZ*	19	3.73	67	250	1SPZ*
42	2.50	100	250	1SPZ*	20	3.52	71	250	1SPZ*
44	2.39	67	160	2SPZ	21	3.33	75	250	1SPZ*
48	2.22	90	200	1SPZ*	22	3.20	125	400	1SPZ*
50	2.11	95	200	1SPZ*	23	3.12	80	250	1SPZ*
53	2.00	100	200	1SPZ*	24	2.99	67	200	1SPZ*
57	1.87	75	140	2SPZ	25	2.82	71	200	1SPZ*
59	1.79	112	200	1SPZ*	26	2.69	67	180	1SPZ*
63	1.67	75	125	2SPZ	28	2.54	71	180	1SPZ*
66	1.61	112	180	1SPZ*	30	2.39	67	160	1SPZ*
70	1.51	106	160	1SPA*	31	2.25	71	160	1SPZ*
73	1.44	125	180	1SPZ*	33	2.13	75	160	1SPZ*
76	1.40	80	112	2SPZ	34	2.09	67	140	2SPZ
80	1.32	85	112	2SPZ	36	1.97	71	140	1SPZ*
83	1.27	118	150	1SPA*	37	1.89	95	180	1SPZ*
85	1.24	90	112	2SPZ	38	1.87	75	140	1SPZ*
87	1.21	132	160	1SPA*	40	1.75	80	140	1SPZ*
89	1.19	118	140	1SPA*	41	1.70	106	180	1SPA*
93	1.14	132	150	1SPA*	42	1.68	95	160	1SPZ*
95	1.11	90	100	2SPZ	43	1.65	85	140	1SPZ*
100	1.06	125	132	1SPZ*	44	1.60	100	160	1SPZ*
106	1.00	95	95	2SPZ	45	1.56	80	125	1SPZ*
112	1.06	132	125	1SPA*	46	1.53	118	180	1SPA*
119	1.12	140	125	1SPA*	47	1.50	100	150	1SPA*
125	1.18	112	95	2SPZ	48	1.47	85	125	1SPZ*
127	1.20	90	75	3SPZ	49	1.44	125	180	1SPZ*
132	1.24	112	90	2SPZ	50	1.42	67	95	2SPZ
134	1.27	95	75	3SPZ	51	1.39	90	125	1SPZ*
136	1.29	180	140	1SPA*	52	1.34	67	90	2SPZ
139	1.32	125	95	2SPZ	53	1.33	75	100	2SPZ
141	1.33	100	75	3SPZ	54	1.32	95	125	1SPZ*
144	1.36	180	132	1SPA*	55	1.28	125	160	1SPZ*
147	1.39	125	90	2SPZ	56	1.27	67	85	2SPZ
152	1.44	180	125	1SPA*	57	1.24	90	112	1SPZ*
156	1.47	140	95	2SPZ	59	1.19	67	80	2SPZ
158	1.49	112	75	3SPZ	60	1.18	95	112	1SPZ*
161	1.53	180	118	1SPA*	62	1.14	140	160	1SPZ*
165	1.56	140	90	2SPZ	63	1.12	67	75	2SPZ
169	1.60	200	125	1SPA*	66	1.07	75	80	2SPZ
174	1.65	140	85	3SPZ	67	1.06	71	75	2SPZ
176	1.67	125	75	3SPZ	70	1.00	100	100	1SPA*
179	1.69	200	118	1SPA*	74	1.05	100	95	2SPZ

*Whilst one belt is adequate for power transmission, two belts can be used without overloading the gearbox bearings. For other speeds, consult Fenner.

Shaft Mounted Speed Reducer Plus Series

Table: 11-16 Belt Drives-1440 Rev/min Motor

D 13 : 1

D 20 : 1

Output Speed Rev/Min	Pulley Ratio	Pulley Dia (mm)		Number of Belts	Output Speed Rev/Min	Pulley Ratio	Pulley Dia (mm)		Number of Belts
		Motor	Gearbox				Motor	Gearbox	
11	9.40	67	630	3SPZ	10	7.04	71	500	2SPZ
14	7.46	67	500	2SPZ	11	6.25	80	500	2SPZ
18	5.97	67	400	2SPZ	12	5.97	67	400	1SPZ*
19	5.63	71	400	1SPZ*	13	5.63	71	400	1SPZ*
21	5.00	80	400	1SPZ*	14	5.00	80	400	1SPZ*
22	4.71	85	400	1SPZ*	15	4.70	67	315	1SPZ*
25	4.21	95	400	1SPZ*	16	4.44	71	315	1SPZ*
26	4.00	100	400	1SPZ*	17	4.20	75	315	1SPZ*
28	3.73	67	250	2SPZ	18	3.94	80	315	1SPZ*
30	3.50	90	315	1SPZ*	19	3.73	67	250	1SPZ*
34	3.15	100	315	1SPZ*	20	3.52	71	250	1SPZ*
36	2.97	106	315	1SPA*	21	3.33	75	250	1SPZ*
38	2.82	71	200	2SPZ	22	3.20	125	400	1SPZ*
40	2.67	75	200	2SPZ	23	3.12	80	250	1SPZ*
42	2.50	100	250	1SPA*	24	2.94	85	250	1SPZ*
44	2.40	75	180	2SPZ	25	2.78	90	250	1SPZ*
47	2.25	80	180	2SPZ	26	2.69	67	180	2SPZ
50	2.12	85	180	2SPZ	27	2.63	95	250	1SPZ*
53	2.00	90	180	2SPZ	28	2.50	100	250	1SPZ*
56	1.89	95	180	2SPZ	30	2.35	85	200	1SPZ*
60	1.78	90	160	2SPZ	32	2.22	90	200	1SPZ*
63	1.68	95	160	2SPZ	33	2.13	75	160	2SPZ
64	1.65	85	140	3SPZ	34	2.09	67	140	2SPZ
66	1.60	125	200	1SPA*	35	2.00	100	200	1SPZ*
70	1.52	132	200	1SPA*	37	1.89	95	180	1SPZ*
71	1.50	100	150	2SPA	38	1.87	67	125	2SPZ
72	1.47	85	125	3SPZ	39	1.80	100	180	1SPZ*
74	1.43	140	200	1SPA*	40	1.75	80	140	2SPZ
76	1.39	90	125	3SPZ	41	1.70	106	180	1SPA*
79	1.33	150	200	1SPA*	42	1.67	75	125	2SPZ
80	1.32	85	112	3SPZ	44	1.61	112	180	1SPZ*
82	1.29	140	180	1SPA*	45	1.58	71	112	2SPZ
85	1.25	112	140	2SPZ	46	1.53	118	180	1SPA*
88	1.20	150	180	1SPA*	47	1.49	75	112	2SPZ
90	1.18	85	100	4SPZ	49	1.44	125	180	1SPZ*
92	1.14	140	160	2SPZ	50	1.40	80	112	2SPZ
94	1.12	160	180	1SPA*	51	1.39	90	125	2SPZ
100	1.06	100	106	3SPA	52	1.34	67	90	3SPZ
101	1.05	112	118	2SPA	53	1.32	106	140	1SPA*
106	1.00	100	100	3SPZ	55	1.28	125	160	1SPZ*
112	1.05	118	112	2SPA	56	1.27	67	85	3SPZ
118	1.11	200	180	1SPA*	58	1.21	132	160	1SPA*
120	1.14	150	132	2SPA	59	1.20	125	150	1SPA*
125	1.18	132	112	2SPA	60	1.18	85	100	2SPZ
127	1.20	150	125	2SPA	62	1.14	140	160	1SPZ*
128	1.21	160	132	2SPA	63	1.11	90	100	2SPZ
132	1.25	200	160	1SPA*	66	1.07	140	150	1SPA
135	1.27	150	118	2SPA	67	1.06	90	95	2SPZ
136	1.29	180	140	2SPA	70	1.00	125	125	1SPA
139	1.32	125	95	3SPZ	74	1.06	132	125	1SPA

**Whilst one belt is adequate for power transmission, two belts can be used without overloading the gearbox bearings. For other speeds, consult Fenner.*



Shaft Mounted Speed Reducer Plus Series

Table: 11-17 Belt Drives-1440 Rev/min Motor

E 13 : 1

E 20 : 1

Output Speed Rev/Min	Pulley Ratio	Pulley Dia (mm)		Number of Belts	Output Speed Rev/Min	Pulley Ratio	Pulley Dia (mm)		Number of Belts
		Motor	Gearbox				Motor	Gearbox	
11	9.40	67	630	3SPZ	10	7.04	71	500	2SPZ
13	8.40	75	630	2SPZ	11	6.25	80	500	2SPZ
14	7.46	67	500	2SPZ	12	5.97	67	400	1SPZ*
16	6.67	75	500	2SPZ	13	5.63	71	400	1SPZ*
18	5.97	67	400	2SPZ	14	5.00	80	400	1SPZ*
19	5.63	71	400	2SPZ	15	4.71	85	400	1SPZ*
21	5.00	100	500	1SPA*	16	4.44	90	400	1SPZ*
24	4.44	71	315	2SPZ	17	4.21	95	400	1SPZ*
25	4.20	75	315	2SPZ	18	4.00	100	400	1SPZ*
26	4.00	100	400	1SPA*	19	3.71	85	315	1SPZ*
28	3.77	106	400	1SPA*	20	3.52	71	250	2SPZ
31	3.39	118	400	1SPA*	21	3.32	95	315	1SPZ*
33	3.20	125	400	1SPA*	22	3.15	100	315	1SPZ*
35	3.03	132	400	1SPA*	23	3.12	80	250	2SPZ
36	2.94	85	250	2SPZ	24	2.99	67	200	2SPZ
38	2.78	90	250	2SPZ	25	2.82	71	200	2SPZ
40	2.63	95	250	2SPZ	26	2.67	75	200	2SPZ
42	2.52	125	315	1SPA*	28	2.54	71	180	2SPZ
44	2.39	132	315	1SPA*	29	2.40	75	180	2SPZ
45	2.35	85	200	3SPZ	30	2.35	85	200	2SPZ
47	2.25	80	180	3SPZ	31	2.25	80	180	2SPZ
50	2.12	85	180	3SPZ	33	2.13	75	160	3SPZ
53	2.00	100	200	2SPA	34	2.09	67	140	3SPZ
55	1.89	95	180	3SPZ	35	2.00	80	160	2SPZ
56	1.89	106	200	2SPA	37	1.88	85	160	2SPZ
59	1.79	112	200	2SPA	38	1.87	67	125	3SPZ
60	1.75	180	315	1SPA*	39	1.79	112	200	1SPA*
62	1.70	106	180	2SPA	40	1.75	180	315	1SPA*
65	1.61	112	180	2SPA	42	1.69	118	200	1SPA*
66	1.60	100	160	3SPZ	43	1.65	85	140	3SPZ
69	1.53	118	180	2SPA	44	1.60	125	200	1SPA*
71	1.50	100	150	3SPA	45	1.56	160	250	1SPA*
73	1.44	125	180	3SPA	46	1.53	118	180	2SPA
74	1.43	140	200	2SPA	47	1.52	132	200	1SPA*
76	1.39	180	250	2SPA	48	1.47	95	140	2SPZ
78	1.36	132	180	2SPA	49	1.44	125	180	1SPA*
79	1.34	112	150	3SPA	50	1.40	100	140	2SPZ
80	1.32	100	132	3SPA	52	1.36	132	180	1SPA*
82	1.29	140	180	2SPA	53	1.33	150	200	1SPA*
83	1.28	125	160	2SPA	54	1.32	95	125	3SPZ
85	1.25	200	250	1SPA*	55	1.27	118	150	2SPA
87	1.21	132	160	2SPA	56	1.25	100	125	2SPA
89	1.18	112	132	3SPA	58	1.21	132	160	2SPA
90	1.18	170	200	2SPB	59	1.20	150	180	1SPA*
93	1.14	140	160	2SPA	60	1.18	106	125	2SPA
95	1.12	125	140	3SPZ	62	1.14	140	160	2SPZ
99	1.07	140	150	2SPA	63	1.11	90	100	3SPZ
100	1.06	100	106	4SPA	66	1.07	140	150	2SPA
101	1.05	95	100	5SPZ	67	1.06	106	112	2SPA
106	1.00	112	112	4SPZ	70	1.00	160	160	1SPA*

**Whilst one belt is adequate for power transmission, two belts can be used without overloading the gearbox bearings. For other speeds, consult Fenner.*

Shaft Mounted Speed Reducer Plus Series

Table: 11-18 Belt Drives-1440 Rev/min Motor

F 13 : 1

F 20 : 1

Output Speed Rev/Min	Pulley Ratio	Pulley Dia (mm)		Number of Belts	Output Speed Rev/Min	Pulley Ratio	Pulley Dia (mm)		Number of Belts
		Motor	Gearbox				Motor	Gearbox	
10	10.67	75	800	3SPZ	10	7.04	71	500	2SPZ
11	9.40	67	630	3SPZ	11	6.67	75	500	2SPZ
13	8.40	75	630	3SPZ	12	5.97	67	400	2SPZ
14	7.46	67	500	2SPZ	13	5.63	71	400	2SPZ
15	7.04	71	500	2SPZ	14	5.00	80	400	2SPZ
17	6.30	100	630	1SPA*	15	4.70	67	315	2SPZ
19	5.60	112	630	1SPA*	16	4.44	71	315	2SPZ
21	5.04	125	630	1SPA*	17	4.20	75	315	2SPZ
24	4.44	90	400	2SPZ	18	4.00	100	400	1SPA*
25	4.24	118	500	1SPA*	19	3.77	106	400	1SPA*
26	4.00	125	500	1SPA*	20	3.57	112	400	1SPA*
28	3.79	132	500	1SPA*	21	3.39	118	400	1SPA*
30	3.57	140	500	1SPA*	22	3.20	125	400	1SPZ*
32	3.33	150	500	1SPA*	23	3.03	132	400	1SPA*
34	3.15	100	315	2SPA	24	2.94	85	250	2SPZ
36	2.97	106	315	2SPA	25	2.86	140	400	1SPZ*
38	2.81	112	315	2SPA	26	2.67	118	315	1SPA
39	2.67	118	315	2SPA	27	2.63	95	250	2SPZ
40	2.63	190	500	2SPB	28	2.50	80	200	3SPZ
42	2.50	100	250	3SPZ	29	2.40	75	180	3SPZ
45	2.36	106	250	3SPA	30	2.39	132	315	1SPA*
47	2.25	140	315	2SPZ	31	2.25	80	180	3SPZ
48	2.22	180	400	1SPZ	33	2.17	85	180	3SPZ
50	2.12	118	250	2SPA	35	2.00	100	200	2SPA
53	2.00	100	200	3SPA	36	1.97	160	315	1SPA*
55	1.89	132	250	2SPA	37	1.88	85	160	3SPZ
56	1.89	106	200	3SPA	39	1.79	112	200	2SPZ
58	1.80	100	180	4SPZ	40	1.75	80	140	4SPZ
60	1.75	180	315	2SPA	42	1.70	106	180	2SPA
63	1.68	95	160	5SPZ	43	1.65	85	140	4SPZ
66	1.61	112	180	3SPA	44	1.60	125	200	2SPZ
68	1.56	160	250	2SPA	45	1.56	160	250	1SPA*
69	1.53	118	180	3SPA	46	1.53	118	180	2SPA
71	1.50	100	150	4SPA	47	1.50	100	150	3SPA
74	1.44	125	180	4SPZ	48	1.48	160	236	2SPB
76	1.40	100	140	5SPZ	49	1.43	112	160	2SPA
78	1.36	132	180	3SPA	50	1.40	100	140	3SPZ
80	1.32	160	212	2SPB	51	1.39	180	250	1SPA*
81	1.32	170	224	2SPB	52	1.36	118	160	2SPA
83	1.28	125	160	3SPA	53	1.32	100	132	3SPA
85	1.25	160	200	2SPA	55	1.29	140	180	2SPZ
88	1.21	132	160	3SPA	56	1.25	100	125	3SPA
89	1.19	118	140	4SPA	58	1.21	132	160	2SPA
90	1.18	170	200	2SPB	59	1.20	125	150	2SPA
93	1.14	132	150	3SPA	60	1.18	106	125	3SPA
95	1.12	118	132	4SPA	62	1.14	132	150	2SPA
99	1.06	160	170	2SPB	63	1.11	106	118	3SPA
100	1.06	118	125	4SPA	66	1.06	132	140	2SPA
106	1.00	140	140	4SPZ	67	1.05	112	118	3SPA
112	1.06	170	160	2SPB	70	1.00	200	200	2SPA

**Whilst one belt is adequate for power transmission, two belts can be used without overloading the gearbox bearings. For other speeds, consult Fenner.*



Shaft Mounted Speed Reducer Plus Series

Table: 11-19 Belt Drives-1440 Rev/min Motor

G 13 : 1

G 20 : 1

Output Speed Rev/Min	Pulley Ratio	Pulley Dia (mm)		Number of Belts	Output Speed Rev/Min	Pulley Ratio	Pulley Dia (mm)		Number of Belts
		Motor	Gearbox				Motor	Gearbox	
11	9.40	67	630	3SPZ	10	7.04	71	500	2SPZ
12	8.87	71	630	3SPZ	11	6.25	80	500	2SPZ
13	8.40	75	630	3SPZ	12	5.97	67	400	3SPZ
14	7.41	85	630	3SPZ	13	5.33	75	400	3SPZ
15	7.04	71	500	3SPZ	14	5.00	80	400	2SPZ
16	6.63	95	630	3SPZ	15	4.71	85	400	2SPZ
17	6.30	100	630	2SPA	16	4.44	90	400	2SPZ
18	5.88	85	500	3SPZ	17	4.21	95	400	2SPZ
19	5.62	112	630	3SPZ	18	4.00	100	400	2SPZ
20	5.26	95	500	3SPZ	19	3.71	85	315	32SPZ
21	5.00	80	400	3SPZ	20	3.57	112	400	2SPZ
22	4.77	132	630	2SPA	21	3.33	150	500	2SPA
23	4.72	106	500	2SPA	22	3.20	125	400	2SPZ
24	4.46	112	500	2SPZ	23	3.03	132	400	2SPA
25	4.21	95	400	3SPZ	24	2.94	85	250	3SPZ
27	4.00	125	500	2SPZ	25	2.78	90	250	3SPZ
28	3.77	106	400	2SPA	26	2.67	150	400	1SPA*
30	3.57	140	500	2SPZ	27	2.63	95	250	3SPZ
31	3.39	118	400	2SPA	28	2.52	125	315	2SPZ
33	3.20	125	400	2SPA	30	2.36	106	250	3SPA
34	2.15	100	315	3SPA	31	2.25	140	315	2SPZ
36	2.97	106	315	3SPA	32	2.23	112	250	2SPA
38	2.81	112	315	3SPZ	33	2.12	118	250	2SPA
40	2.63	95	250	5SPZ	34	2.10	150	315	2SPA
42	2.50	100	250	4SPZ	35	2.00	100	200	3SPA
44	2.39	132	315	2SPA	36	1.97	160	315	2SPA
45	2.36	106	250	3SPA	37	1.89	95	180	4SPZ
47	2.25	140	315	2SPA	39	1.80	100	180	4SPZ
50	2.11	95	200	5SPZ	40	1.75	180	315	2SPA
53	2.00	100	200	4SPA	41	1.70	106	180	3SPA
56	1.89	132	250	3SPA	42	1.67	150	250	2SPA
57	1.85	170	315	2SPB	44	1.60	125	200	3SPZ
59	1.79	140	250	4SPZ	45	1.56	160	250	2SPA
61	1.75	180	315	2SPA	47	1.50	100	150	4SPA
63	1.69	118	200	4SPA	48	1.47	95	140	5SPZ
64	1.65	170	280	2SPB	49	1.43	112	160	4SPZ
66	1.60	125	200	5SPZ	50	1.40	100	140	4SPA
70	1.53	118	180	4SPA	51	1.39	180	250	2SPA
72	1.48	160	236	2SPB	52	1.36	118	160	3SPA
74	1.43	140	200	3SPA	53	1.33	150	200	2SPA
76	1.39	170	236	2SPB	55	1.28	125	160	3SPA
80	1.33	150	200	3SPA	56	1.25	160	140	2SPA
83	1.27	118	150	5SPA	58	1.21	132	250	3SPA
85	1.24	180	224	2SPB	59	1.20	125	160	3SPA
87	1.21	132	160	4SPA	60	1.18	170	200	2SPB
90	1.18	180	212	2SPB	62	1.14	132	150	3SPA
93	1.14	140	160	4SPA	63	1.11	180	200	2SPA
95	1.11	180	200	3SPA	66	1.07	140	150	3SPA
100	1.06	212	224	2SPB	67	1.05	190	200	2SPB
					70	1.00	180	180	2SPB

**Whilst one belt is adequate for power transmission, two belts can be used without overloading the gearbox bearings. For other speeds, consult Fenner.*

Shaft Mounted Speed Reducer Plus Series

Table: 11-20 Belt Drives-1440 Rev/min Motor

H 13 : 1

H 20 : 1

Output Speed Rev/Min	Pulley Ratio	Pulley Dia (mm)		Number of Belts	Output Speed Rev/Min	Pulley Ratio	Pulley Dia (mm)		Number of Belts
		Motor	Gearbox				Motor	Gearbox	
10	10.67	75	800	3SPZ	10	7.04	71	500	3SPZ
11	9.41	85	800	3SPZ	11	6.63	95	630	3SPZ
12	8.89	90	800	3SPZ	12	5.88	85	500	3SPZ
13	8.82	95	800	3SPZ	13	5.56	90	500	3SPZ
14	7.87	80	630	3SPZ	14	5.04	125	630	2SPA
16	6.63	95	630	3SPZ	15	4.71	85	400	3SPZ
18	5.94	106	630	2SPA	16	4.44	90	400	3SPZ
19	5.62	112	630	2SPA	17	4.24	118	500	2SPA
21	5.00	100	500	3SPA	18	4.00	125	500	2SPZ
23	4.72	106	500	3SPA	19	3.77	106	400	3SPA
25	4.21	95	400	5SPZ	20	3.57	112	400	2SPA
27	4.00	100	400	4SPZ	21	3.39	118	400	2SPA
28	3.77	106	400	4SPA	22	3.20	125	400	2SPA
30	3.57	140	500	2SPA	23	3.03	132	400	2SPA
32	3.33	150	500	2SPA	24	2.97	106	315	3SPA
34	3.15	100	315	5SPZ	25	2.86	140	400	2SPA
35	3.03	132	400	3SPA	26	2.67	150	400	2SPA
37	2.86	140	400	4SPZ	27	2.63	95	250	5SPZ
38	2.78	180	500	2SPA	28	2.52	125	315	4SPZ
40	2.67	118	315	4SPA	30	2.36	106	250	4SPA
42	2.50	160	400	2SPB	31	2.25	140	315	3SPZ
44	2.39	132	315	4SPA	32	2.23	112	250	4SPZ
45	2.35	170	400	2SPB	33	2.12	118	250	3SPA
47	2.25	140	315	5SPZ	34	2.10	150	315	2SPA
48	2.22	180	400	2SPB	35	2.00	125	250	3SPA
50	2.10	150	315	3SPA	36	1.97	160	315	2SPA
51	2.09	170	355	2SPB	37	1.89	132	250	3SPA
54	1.97	160	315	2SPB	38	1.85	170	315	2SPB
56	1.89	132	250	4SPA	39	1.79	140	250	4SPZ
57	1.87	190	355	2SPB	40	1.75	180	315	2SPA
59	1.79	140	250	4SPA	41	1.70	106	180	5SPA
61	1.75	180	315	2SPB	42	1.69	118	200	4SPA
64	1.66	190	315	2SPB	44	1.60	125	200	5SPZ
67	1.60	250	400	2SPB	45	1.57	200	315	2SPA
68	1.56	160	250	3SPB	47	1.52	132	200	4SPA
72	1.48	160	236	3SPB	48	1.47	170	250	2SPB
74	1.43	140	200	5SPA	49	1.44	125	180	4SPA
76	1.39	180	250	3SPB	51	1.39	170	236	2SPB
79	1.33	236	315	2SPB	52	1.36	132	180	4SPA
80	1.33	150	200	5SPA	53	1.33	150	200	3SPA
82	1.29	140	180	5SPA	54	1.31	180	236	2SPB
85	1.25	224	280	2SPB	55	1.27	118	150	5SPA
90	1.18	180	212	3SPB	57	1.24	180	224	2SPB
95	1.11	180	200	4SPA	59	1.20	125	150	5SPA
100	1.06	212	224	3SPB	60	1.18	190	224	2SPB
					62	1.14	140	160	4SPA
					63	1.11	180	200	3SPA
					66	1.07	150	160	4SPA
					67	1.05	190	190	3SPB
					70	1.00	212	212	2SPB

**Whilst one belt is adequate for power transmission, two belts can be used without overloading the gearbox bearings. For other speeds, consult Fenner.*



Shaft Mounted Speed Reducer Plus Series

Table: 11-21 Belt Drives-1440 Rev/min Motor

J 13 : 1

J 20 : 1

Output Speed Rev/Min	Pulley Ratio	Pulley Dia (mm)		Number of Belts	Output Speed Rev/Min	Pulley Ratio	Pulley Dia (mm)		Number of Belts
		Motor	Gearbox				Motor	Gearbox	
11	10.00	100	1000	3SPA	10	7.00	90	630	3SPZ
12	8.89	90	800	4SPZ	11	6.30	100	630	3SPZ
13	8.00	100	800	3SPA	12	5.94	106	630	3SPA
14	7.55	106	800	3SPA	13	5.62	112	630	3SPZ
15	7.14	112	800	3SPA	14	5.00	100	500	3SPA
16	6.63	95	630	5SPZ	15	4.72	106	500	3SPA
17	6.40	125	800	3SPZ	16	4.50	140	630	2SPA
18	5.94	106	630	4SPA	17	4.21	95	400	5SPZ
19	5.62	112	630	3SPA	18	4.00	100	400	4SPA
21	5.04	125	630	4SPZ	19	3.77	106	400	4SPA
22	4.77	132	630	3SPA	20	3.57	140	500	3SPZ
23	4.72	106	500	4SPA	21	3.39	118	400	3SPA
24	4:50	140	630	4SPZ	22	3.20	125	400	3SPA
25	4.24	118	500	4SPA	23	3.03	132	400	3SPA
27	3.94	160	630	2SPB	24	2.94	170	500	2SPB
29	3.71	170	630	2SPB	25	2.78	180	500	2SPA
30	3.57	140	500	4SPA	26	2.67	118	315	4SPA
32	3.33	150	500	3SPA	27	2.63	190	500	2SPB
34	3.12	160	500	3SPA	28	2.52	125	315	5SPZ
35	3.03	132	400	4SPA	30	2.35	170	400	2SPB
37	2.86	140	400	4SPA	31	2.25	140	315	5SPZ
38	2.78	180	500	3SPA	32	2.22	180	400	2SPB
40	2.63	190	500	2SPB	33	2.12	118	250	5SPA
42	2.50	160	400	3SPB	34	2.09	170	355	3SPB
44	2.39	132	315	5SPA	35	2.01	236	475	3SPC
45	2.36	212	500	2SPB	36	1.97	160	315	3SPA
47	2.25	355	800	3SPB	37	1.91	236	450	3SPC
48	2.22	180	400	3SPB	38	1.87	190	355	2SPB
50	2.12	224	475	3SPC	39	1.79	140	250	4SPA
51	2.09	170	355	3SPB	40	1.75	180	315	3SPA
53	2.00	200	400	3SPA	41	1.70	250	425	3SPC
54	1.97	160	315	4SPB	42	1.67	150	250	4SPA
56	1.90	224	425	3SPC	43	1.65	170	280	3SPB
57	1.87	190	355	3SPB	44	1.60	125	200	6SPA
59	1.79	140	250	6SPA	45	1.57	200	315	3SPA
61	1.75	180	315	4SPA	47	1.49	212	315	2SPB
64	1.66	190	315	3SPB	48	1.47	190	280	3SPB
67	1.57	200	315	4SPA	49	1.43	140	200	5SPA
68	1.56	180	280	4SPB	51	1.39	170	236	3SPB
71	1.49	212	315	3SPB	53	1.33	150	200	5SPA
72	1.47	170	250	5SPB	54	1.31	180	236	3SPB
74	1.43	280	400	2SPB	55	1.29	140	180	6SPA
76	1.39	180	250	5SPA	56	1.25	200	250	4SPA
79	1.33	236	315	3SPB	57	1.24	190	236	3SPB
81	1.32	190	250	4SPB	59	1.19	160	190	4SPB
83	1.27	315	400	2SPB	60	1.18	200	236	3SPB
85	1.24	190	236	4SPB	63	1.12	160	180	5SPA
89	1.19	236	280	3SPB	66	1.06	236	250	3SPB
95	1.12	250	280	3SPB	67	1.06	170	180	4SPB
100	1.06	212	224	4SPB	70	1.00	280	280	2SPB

**Whilst one belt is adequate for power transmission, two belts can be used without overloading the gearbox bearings. For other speeds, consult Fenner.*

Shaft Mounted Speed Reducer Plus Series

Gearbox Installation - SMSR Plus

Note: Satisfactory performance depends on proper installation, lubrication & maintenance. Therefore, it is important that instructions in the Installation & Maintenance manual supplied with each gearbox are followed carefully. Some of the important aspects of belt and torque-arm installation are listed hereunder ;-

1. Install pulley on gearbox input shaft as close to the Reducer as possible. See Fig.1., Failure to do this will cause excess load on the input shaft bearings leading to their premature failure.
2. Install motor and Wedge Belt drive with the belt pull at approximately 90° to the centre line between driven and input shafts. See Fig. 2. This will permit tensioning of the V-Belt drive with the torque-arm, which should preferably be in tension. If output hub runs anti-clockwise, torque-arm should be positioned to the right. See Fig. 3.
3. Install torque-arm fulcrum on a rigid support so that the torque-arm will be at approximately right angles to the centre line through the driven shaft and the torque-arm case bolt. See Fig. 4. Make sure there is sufficient take-up in the turn- buckle for belt tension adjustment.

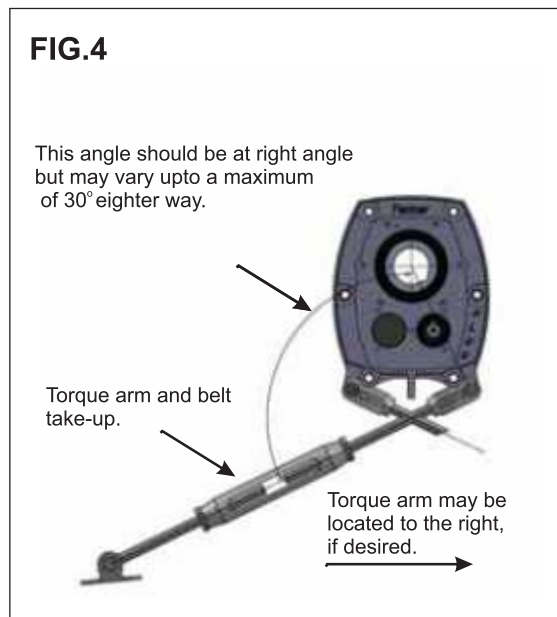
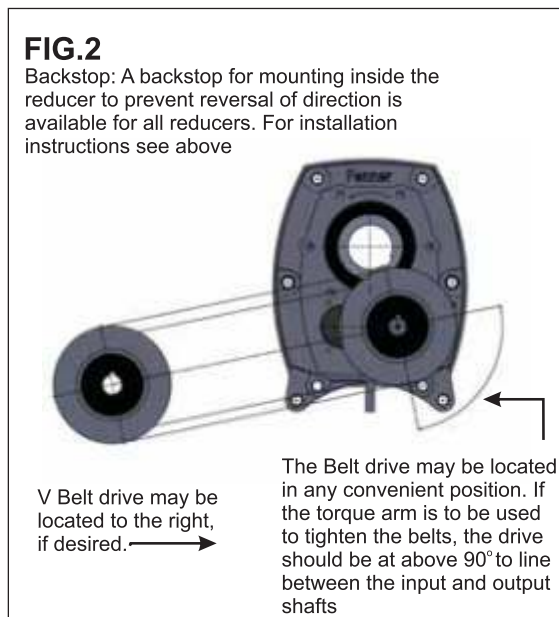
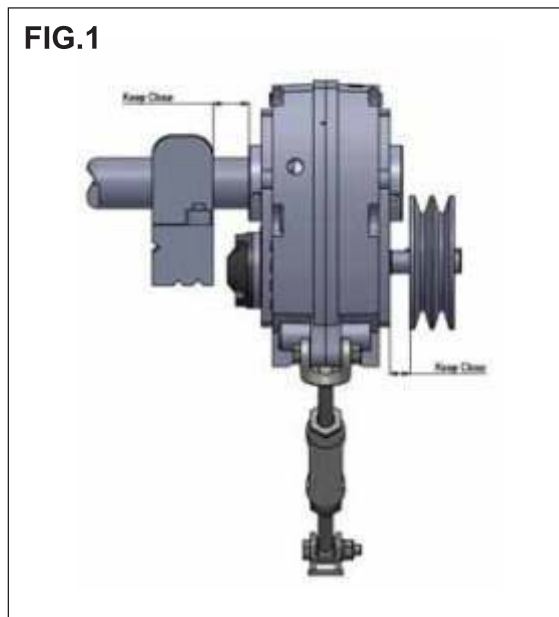



Shaft Mounted Speed Reducer Plus Series

Parts Identification

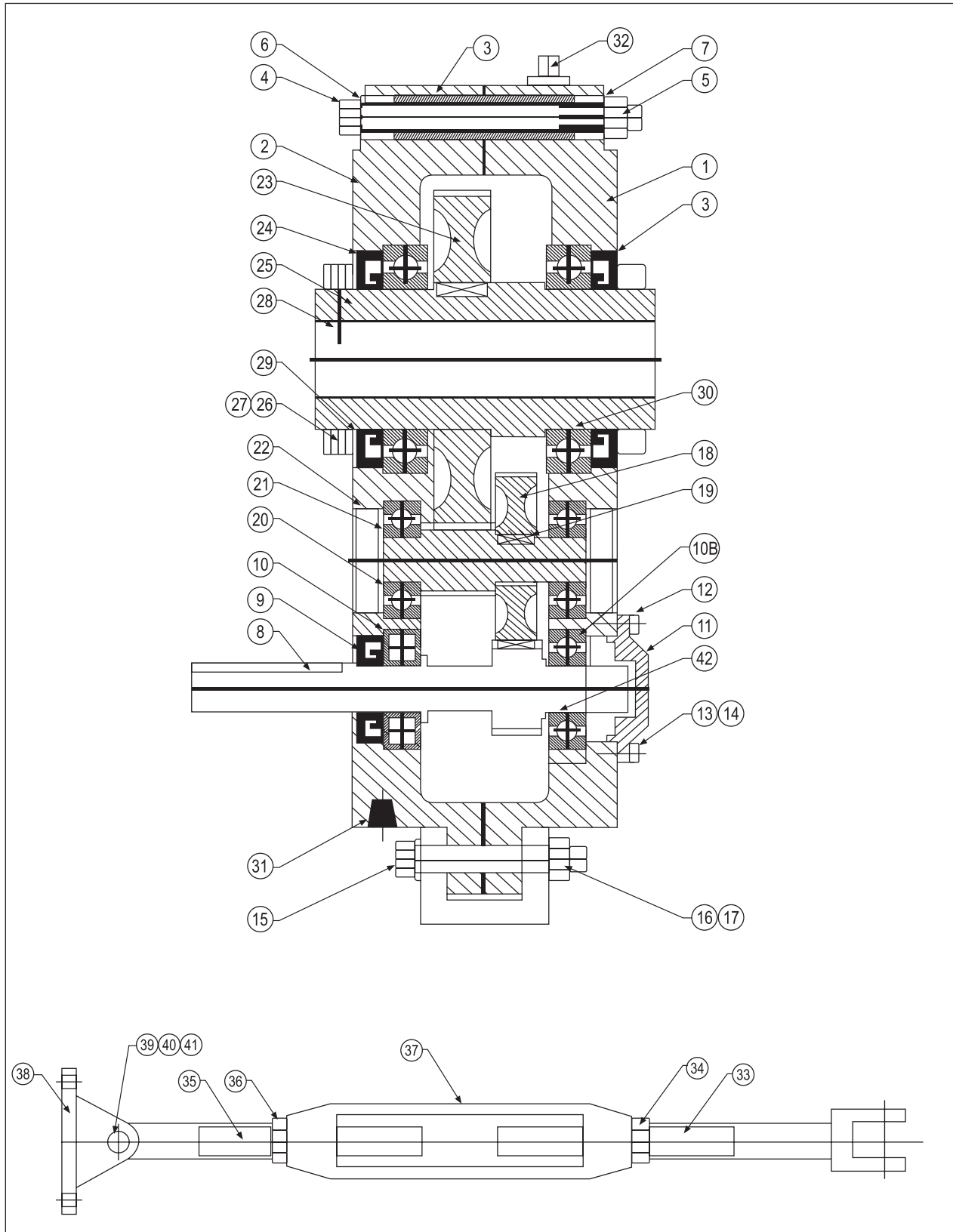

Shaft Mounted Speed Reducer Plus Series

Individual Parts

Ref.No.	Description
1	Case RH
2	Case LH
3	Hollow Dowel
4	Case Bolt
5	Case Nut
6	Case Plain Washer
7	Case Lock Washer
8	Input Shaft & Pinion (5:1, 13:1 & 20:1)
9	Input Shaft Oilseal (5:1, 13:1 & 20:1)
10A	Input Shaft Brg. - Shaft Side (5:1, 13:1 & 20:1)
10B	Input Shaft Brg. - B. stop side (5:1, 13:1 & 20:1)
11	Backshop Cover
12	Backshop Cover Gasket
13	Backshop Cover Screw
14	Backshop Cover Lockwasher
15	Torque-Arm Case Bolt
16	Torque-Arm Case Bolt Nut
17	Torque-Arm Case Bolt Lockwasher
18	1st Reduction Gear (13:1 & 20:1) only
19	1st Reduction Gear Key
20	Intermediate Pinion (13:1 & 20:1)
21	Intermediate Bearing
22	Intermediate Cover
23	2nd Reduction Gear (13:1, 20:1 & 5:1)
24	GearKey
25	Output Hub (standard, Alternative bore)
26	Output Hub collar
27	Collar Screw (Std. & Alternative) over key
28	Collar Screw (Std. & Alternative) over Shaft
29	Output Hub Oilseal
30	Output Hub Bearing
31	Pipe Plug
32	Breather Plug
33	Torque-Arm Rod End
34	Rod End Locknut
35	Torque-Arm Extension
36	Extension Locknut
37	Turnbuckle
38	Fulcrum
39	Fulcrum Bolt
40	Fulcrum Bolt Nut
41	Fulcrum Bolt Lockwasher
42	Input Shaft Spacer (20:1) only

When ordering parts for reducer, please specify:

1. Reducer Size No.
2. Reducer Serial No.
3. Part Name
4. Code Numbers
5. Quantity Required

Note: Inclusion of a gearbox size in this leaflet does not imply availability in all markets.



Shaft Mounted Speed Reducer Plus Series

Installation & Operation of Belt Drives using Fenner Belt Tension Indicator

- Always use a matched set of belts.
- Clean any oil and grease from pulleys; remove any rust or burrs from the grooves.
- Reduce the centre distance until the belts can be put into the pulley grooves without forcing. See table for installation allowance. Make sure the pulleys are correctly aligned and that the shafts are parallel.
- Place the belts into the pulley grooves and tension the drive.

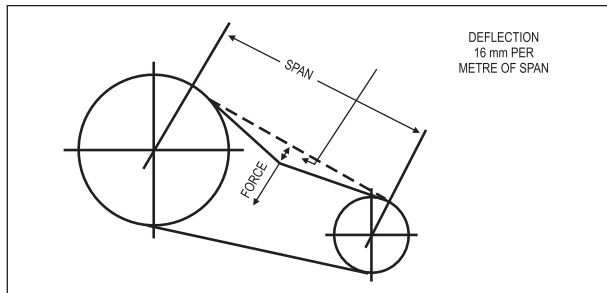

Fenner Belt Tension Indicator

The high performance and efficiency of Fenner Precision Built Wedge Belts require correct tension. We recommend using the Fenner Belt Tension Indicator.

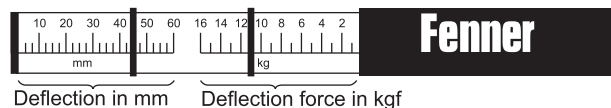

Method of Belt Tensioning

1. Calculate the deflection distance in mm on a basis of 16mm per metre of span.
Centre Distance (m) x 16 = Deflection (mm).
2. Set the lower marker ring at the deflection distance required in mm on the lower scale.
3. Set the upper marker ring against the bottom edge of the tube.
4. Place the Belt Tension Indicator on top of the belt at the centre of span and apply a force at right angles to the belt deflecting it to the point where the lower marker ring is level with the top of the adjacent belt*.
5. Read off the force value indicated by the top edge of the upper marker ring.
6. Compare this force to the kgf value shown in the table opposite.
7. If a Fenner Belt Tension Indicator is not available, a spring balance and rule will suffice.

***Note:** For single belt drives a straight edge should be placed across the two pulleys to act as a datum for measuring the amount of deflection.

If the measured force falls within the values given, the drive should be satisfactory. A measured force below the lower value indicates under-tensioning.

A new drive should be tensioned to the higher value to allow for the normal drop in tension during the running-in period. After the drive has been running for 30 minutes, the tension should be checked and re-adjusted to the higher value, if necessary.

Installation and Take-up Allowance Table

Belt Pitch Length	Installation Allowance				Take-up Allowance
	SPZ	SPA	SPB	SPC	
850 to 1160					15
1170 to 1500	20				20
1510 to 1830					25
1840 to 2170					30
2180 to 2830		25			40
2840 to 3500					50
3520 to 4160			30	50	60
4170 to 5140					70
5220 to 6150					85
6180 to 7420					105
7600 to 8390					125

All dimensions are in millimetres.

Storage

V-Belts should be stored in a dry stockroom and contact with hot pipes and direct sunlight carefully avoided.

Wherever possible, handle the belts loosely in single (or triple) coils. Always avoid tying them tightly with thin string.

Guards

Where guards are necessary it is desirable to use the wire mesh type to permit adequate ventilation.

One Shot Tensioning

Fenner PB Belts are built right from the start to ensure totally precise inherent length, to stay matched during storage and on the drive, making "one-shot" tensioning a reality endorsed by satisfied customers.

Simply put the belts around the pulleys, set them to the appropriate tension value stated in the Tension Forces Table (using the Belt Tension Indicator as shown), run the drive under load for 30 minutes, stop the drive, check the tension, re-setting to catalogue value if necessary. On a properly designed drive for the application there will be no need for any further attention during the life of the drive.

Fenner **POLY-F** PLUS PB / Fenner PowerTran

Tensioning Forces

Belt Section	Force required to deflect belt 16mm per metre of span		
	Small Pulley Diameter (mm)	Newton (N)	Kilogramforce (kgf)
SPZ	56 to 95	10 to 15	1.0 to 1.5
	100 to 140	15 to 20	1.5 to 2.0
SPA	90 to 132	20 to 27	2.0 to 2.7
	140 to 200	28 to 35	2.8 to 3.5
SPB	160 to 224	35 to 50	3.5 to 5.1
	236 to 315	50 to 65	5.1 to 6.6
SPC	224 to 355	60 to 90	6.1 to 9.2
	375 to 560	90 to 120	9.2 to 12.2

Shaft Mounted Speed Reducer Plus Series

Replacement of parts

Removing Reducer from shaft

Loosen screws in both output hub collars. Remove the collar next to end of shaft, turn the collar and replace with the flush side outwards. Replace and tighten screws fully and then slacken off slightly in order to have maximum engagement in the hub but not gripping the shaft. Using any suitable three legged hub drawer engage the feet recesses of the collar and remove the gearbox by screwing down on the shaft.

Important

Using tools normally found in the maintenance department, the Reducer can be dismantled and reassembled. Cleanliness is very important to prevent the introduction of dirt into the bearings and other parts of the Reducer. A tank of clean solvent, an arbor press and equipment for heating bearings and gears should be available for shrinking these parts on the shafts.

Rubbing type oilseals are fitted and great care should be taken during dismantling and reassembling to avoid damage to the rubbing surfaces.

The keyseat in the input shaft should be covered with cello tape or other suitable material. Any burrs on shaft or hub surfaces should be carefully removed before fitting seals.

We are prepared to repair reducers for customers who do not have proper facilities or who do for any reason desire factory service. An estimate of the cost will be sent after examination and before the repair is begun.

Ordering Parts

When ordering parts for a Reducer, specify reducer size, serial number, part name, code number, and quantity required.

It is strongly recommended that when a pinion or gear is replaced, the mating gear or pinion be replaced also. If the large gear on the output hub must be replaced, it is recommended that an output hub assembly of a gear assembled on a hub be ordered to secure undamaged surfaces on the outer hub where the oilseals rub.

However, if it is desired to use the old output hub, press the gear and bearing off and examine the rubbing surfaces under the oilseal carefully for possible scratching or other damage resulting from the pressing operation. To prevent oil leakage at the shaft oilseals, the smooth surface of the output hub must not be damaged.

If any part must be pressed from a shaft or from the output hub, this should be done before ordering parts

to make sure that none of the bearings or other parts are damaged on removal. Do not press against the outer race of any bearing. Because old shaft oilseals and gaskets may be damaged in dismantling, it is advisable to order replacements for these parts.

Bolt Tightening Torques

Reducer Size	B	C&D	E	F&G	H&J
Torque Nm	16	30	50	80	50&80
Torque lbf ft	12	22	37	59	37&59*

H&J *Torque-arm case bolts only.

Length

Inches x 25.4 = millimetres

Inches x 0.0254 = metres

Feet x 0.30480 = metres

Yards x 0.91440 = metres

Force

Kilogramforce (kgf) x 9.81 = Newtons (N)

Poundsforce (lbf) x 4.45 = Newtons (N)

Note: The kilopond (kp) is an alternative name for the kilogramforce (kgf)

Torque

Kilogramforce metre

(kgfm) x 9.81 = Newton metre (Nm)

Pounds feet (lbf ft) x 1.36 = Newton metre (Nm)

Pounds inches (lbf in) x 0.113 = Newton metre (Nm)

Power

Horse power (hp) x 0.746 = kilowatt (kW)

Cheval-vapeur (CV) x 0.735 = kilowatt (kW)

Pferdestärke (PS) x 0.735 = kilowatt (kW)

Torque and Power Equivalents

The kilowatt (kW) is the common unit of mechanical power, i.e. the rate of doing work.

Torque is a turning moment or twisting effort and is expressed in Newton metres (Nm)

$$kW = \frac{Nm \times rev/min}{9550} \quad Nm = \frac{kW \times 9550}{rev/min}$$

Pressure

Poundsforce per square inch

(lbf/in²) x 0.0689 = bar

Kilonewtons per square metre

(kN/m²) x 0.01 = bar

Kilogramforce per square centimetre

(kgf/cm²) x 0.981 = bar

Fluid Volume

Gallons x 4.55 = litres

Cubic inches x 0.0164 = litres

Cubic feet x 28.3 = litres

Cubic metres x 1000 = litres

F Shaft Mounted Speed Reducer Plus Series

Backstops Installation - SMSR Plus

If Reducer is filled with oil, drain off oil before proceeding further.

Step 1

Remove backstop cover and gasket ref 11&12 (individual parts)

Step 2

Determine direction of required shaft rotation.

Sizes 'B'Plus to 'J'Plus

The Shaft is free to rotate in the direct on the arrow marked on the backstop cage. If the opposite direction of rotation is required, remove the assembly and turn the sprag assembly through 180° reassemble.

Step 3

Replace gasket ref 11 and 12

Step 4

Refill Reducer with correct grade of oil.

IMPORTANT

When pressing the backstop into the housing it is important to hammer the assembly at any time. The assembly may be tapped gently, if necessary.

The change the backstopping direction at any time, it is necessary to remove the sprag assembly and turn it end for end. Two M3 tapped holes are provided to remove the outer race. On size C no holes are provided; use two bent, pieces of wire to hook and withdraw the sprag, turn end for end and replace.

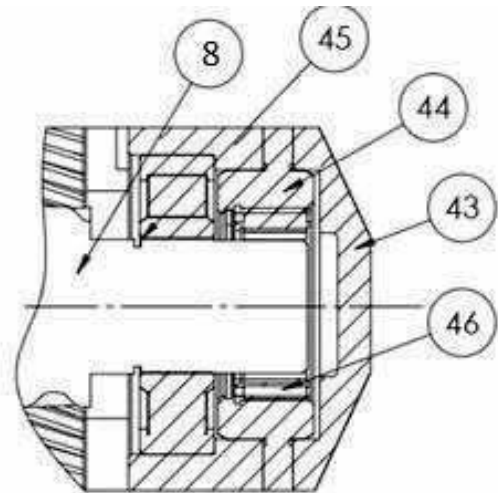
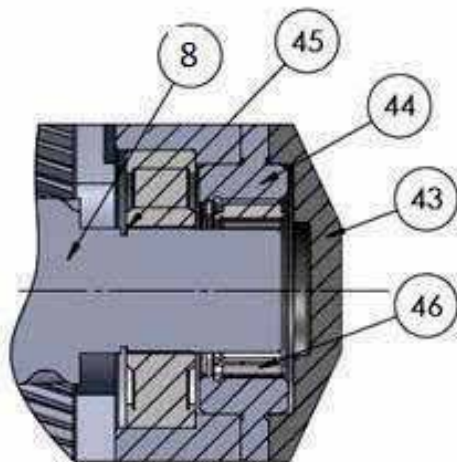

Sizes: B, C, D, E, F, G, H & J

Spare Part ref.No	Description	No. Reqd
43	Back stop Assembly	1
44	Back stop out bush	1
45	Back stop Circlip	1
46	Sprag wheel	1

Shaft Mounted Speed Reducer Plus Series

Applications



Cable winding machine



Conveyor Belt Drive



Screw Conveyor



Conveyor in a Stone Crusher Plant



Hydro Testing Equipment